

# Zero Turn Mowers

ZT360 & ZT372

Accu-Z®

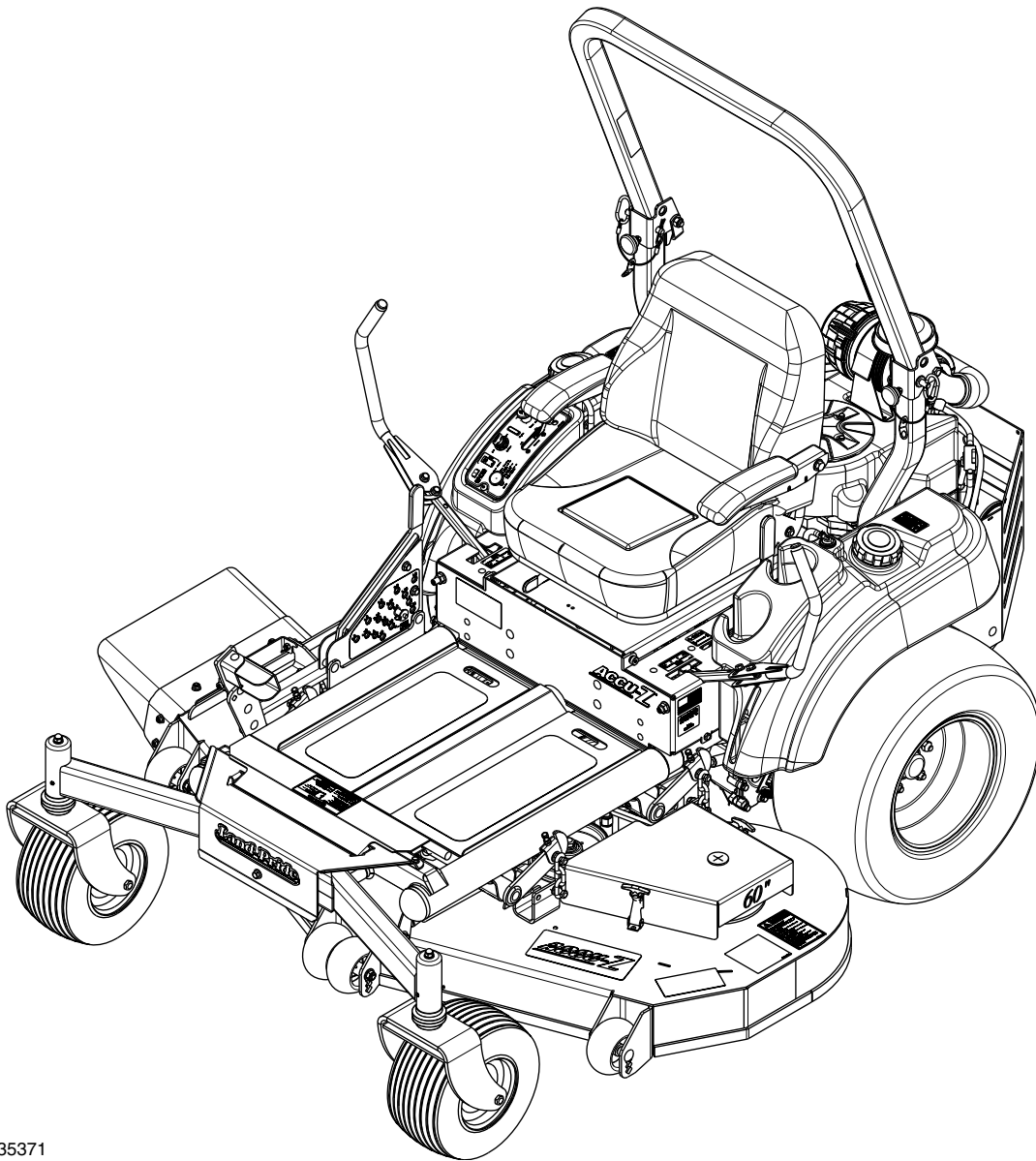

35371

## 357-610M Operator's Manual



Parts Manual QR Code



Read the Operator's Manual entirely. When you see this symbol, the subsequent instructions and warnings are serious - follow without exception. Your life and the lives of others depend on it!

*Cover photo may show optional equipment not supplied with standard unit.*

© Copyright 2015 Printed 12/15/15

<b>Important Safety Information</b> .....	<b>1</b>	Belt Tensioning .....	28
Safety Labels .....	4	Deck Leveling .....	28
<b>Introduction</b> .....	<b>8</b>	Deck Lift Assist Springs .....	30
Application .....	8	Anti-Scalp Rollers .....	30
Using This Manual .....	8	Front Axle Pivot .....	31
Owner Assistance .....	8	<b>Section 4: Options &amp; Accessories</b> .....	<b>32</b>
Serial Number .....	8	Folding Soft Top Canopy .....	32
<b>Section 1: Assembly &amp; Set-up</b> .....	<b>10</b>	Head Light Kit .....	32
Uncrating Instructions .....	10	Safety Flashing Light & SMV Sign Kit .....	32
Torque Requirements .....	10	Lift Jack .....	33
Control Lever Assembly .....	10	Mulching Kit & Blades .....	33
Seat Assembly .....	10	Rear Wheels .....	33
Spring Loaded Seat Release Latch .....	11	Inductive Tachometer .....	33
Discharge Chute Assembly .....	11	<b>Section 5: Maintenance &amp; Lubrication</b> .....	<b>34</b>
Folding ROPS .....	12	Maintenance .....	34
Electrical Cable Connection .....	12	Maintenance Safety .....	34
Engine Preparations .....	13	Maintenance Schedule .....	35
<b>Section 2: Operating Procedures</b> .....	<b>14</b>	Tires .....	36
Mower Features .....	14	Torque Requirements .....	36
Operating Checklist .....	15	Electrical System .....	36
Control Panel .....	15	Belt Maintenance .....	38
Accessing Area Beneath Seat Platform .....	16	Hydrostatic Drive System .....	40
Accessing Area Beneath Floor Pan .....	17	Transaxle Oil Check & Filling .....	40
Moving Mower with Stalled Engine .....	17	Transaxle Oil & Filter Change .....	41
Transport Height .....	18	Transaxle Purging Procedures .....	41
Cutting Height .....	18	Fuel System .....	42
Clearing Obstacles .....	18	Evaporative Emission Control System .....	43
Engine Starting .....	18	Fuel Filter .....	43
Engine Shut-Down Sequence .....	19	Drain Fuel Tank .....	43
Safety Start Interlock System .....	19	General Engine Maintenance .....	43
Driving the Mower .....	19	Engine Oil & Oil Filter .....	44
Towing Using The Rear Hitch .....	21	Engine Air Filter .....	45
Safe Operating Instructions .....	21	Engine Air Filter Handling .....	46
Good Operating Practices .....	23	Mower Blade Maintenance .....	47
General Operating Information .....	23	End of Season & Long Term Storage .....	49
<b>Section 3: Adjustments</b> .....	<b>24</b>	New Season Preparation .....	49
Torque Requirements .....	24	Lubrication Points .....	50
Tire Pressure .....	24	<b>Section 6: Specifications &amp; Capacities</b> .....	<b>53</b>
Park Brake Adjustment .....	24	<b>Section 7: Features &amp; Benefits</b> .....	<b>56</b>
Seat Reach Adjustment .....	25	<b>Section 8: Troubleshooting</b> .....	<b>58</b>
Suspension Seat Weight Adjustment .....	25	<b>Section 9: Torque &amp; Tire Inflation Charts</b> ...	<b>60</b>
Additional Seat Suspension .....	25	<b>Section 10: Warranty</b> .....	<b>62</b>
Deck Lift Pedal Adjustment .....	26		
Steering Adjustments .....	26		
Lower Control Lever .....	26		
Upper Control Lever .....	27		



© Copyright 2015 All rights Reserved

Land Pride provides this publication "as is" without warranty of any kind, either expressed or implied. While every precaution has been taken in the preparation of this manual, Land Pride assumes no responsibility for errors or omissions. Neither is any liability assumed for damages resulting from the use of the information contained herein. Land Pride reserves the right to revise and improve its products as it sees fit. This publication describes the state of this product at the time of its publication, and may not reflect the product in the future.

Land Pride is a registered trademark.

All other brands and product names are trademarks or registered trademarks of their respective holders.

Printed in the United States of America.

**Important Safety Information**

These are common practices that may or may not be applicable to the products described in this manual.

**Safety at All Times**

Thoroughly read and understand the instructions given in this manual before operation. Refer to the "Safety Label" section, read all instructions noted on them.

Do not allow anyone to operate this equipment who has not fully read and comprehended this manual and who has not been properly trained in the safe operation of the equipment.

- ▲ Operator should be familiar with all functions of the mower.
- ▲ The operator must not use drugs or alcohol as they can change the alertness or coordination of that person while operating equipment. The operator should, if taking over-the-counter drugs, seek medical advice on whether he/she can safely operate the equipment.
- ▲ Operate mower from the driver's seat only.
- ▲ Make sure all guards and shields are in place and secured before operating the mower.
- ▲ Do not leave mower unattended with engine running.
- ▲ Dismounting from a moving mower can cause serious injury or death.
- ▲ Do not allow anyone to stand between mower and equipment while backing up to hitch mower to the equipment.
- ▲ Keep hands, feet, and clothing away from power-driven parts.
- ▲ Wear snug fitting clothing to avoid entanglement with moving parts.
- ▲ Watch out for wires, rocks trees, etc., when using the mower. Make sure all persons are clear of working area.
- ▲ Do not carry passengers on the mower at any time.
- ▲ Turning mower too tight may cause hitched machinery to ride up on wheels. This could result in injury or equipment damage.



**Look For The Safety Alert Symbol**

The SAFETY ALERT SYMBOL indicates there is a potential hazard to personal safety involved and extra safety precaution must be taken. When you see this symbol, be alert and carefully read the message that follows it. In addition to design and configuration of equipment, hazard control, and accident prevention are dependent upon the awareness, concern, prudence, and proper training of personnel involved in the operation, transport, maintenance, and storage of equipment.

**Be Aware of Signal Words**

A Signal word designates a degree or level of hazard seriousness. The signal words are:

**▲ DANGER**

Indicates an imminently hazardous situation which, if not avoided, will result in death or serious injury. This signal word is limited to the most extreme situations, typically for machine components that, for functional purposes, cannot be guarded.

**▲ WARNING**

Indicates a potentially hazardous situation which, if not avoided, could result in death or serious injury, and includes hazards that are exposed when guards are removed. It may also be used to alert against unsafe practices.

**▲ CAUTION**

Indicates a potentially hazardous situation which, if not avoided, may result in minor or moderate injury. It may also be used to alert against unsafe practices.

**For Your Protection**

- ▲ Thoroughly read and understand the "Safety Label" section, read all instructions noted on them.

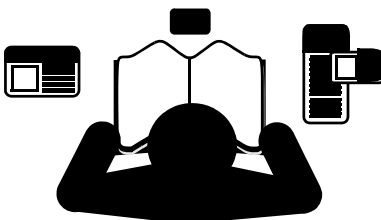

**Shutdown and Storage**

- ▲ Put mower in park, turn off engine, and remove key.
- ▲ Store mower in an area where children normally do not play.

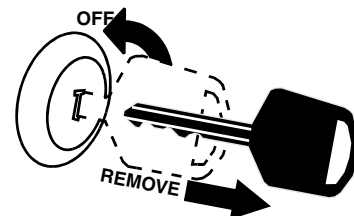

**Manual QR Locator**

The QR (Quick Reference) codes on the cover and below will take you to the Parts Manual for this equipment. Download the appropriate App on your camera phone, open the App, point your phone on the QR code, and take a picture.



ZT360 & ZT372  
Parts Manual



Kawasaki FX850V  
Owner's Manual

**Dealer QR Locator**

The QR code below will link you to available dealers for Land Pride products.



These are common practices that may or may not be applicable to the products described in this manual.

### Prepare for Emergencies

- ▲ Be prepared if a fire starts.
- ▲ Keep a first aid kit and fire extinguisher handy.
- ▲ Keep emergency numbers for doctor, ambulance, hospital, and fire department near phone.

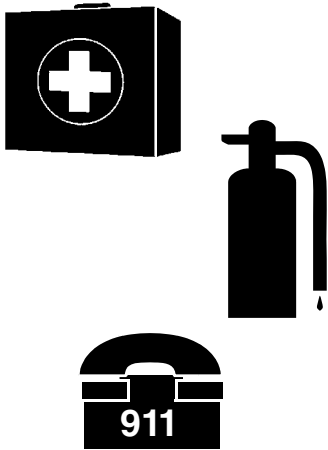

### Tire Safety

- ▲ Tire changing can be dangerous and should be performed by trained personnel using the correct tools and equipment.
- ▲ When inflating tires, use a clip-on chuck and extension hose long enough to allow you to stand to one side and NOT in front of or over the tire assembly. Use a safety cage if available.
- ▲ When removing and installing wheels, use wheel handling equipment adequate for the weight involved.



### Wear Protective Equipment

- ▲ Wear protective clothing and equipment appropriate for the job. Clothing should be snug fitting without fringes and pull strings to avoid entanglement with moving parts.
- ▲ Prolonged exposure to loud noise can cause hearing impairment or hearing loss. Wear suitable hearing protection such as earmuffs or earplugs.
- ▲ Operating equipment safely requires the operator's full attention. Avoid wearing radio headphones while operating machinery.



### Keep Riders Off Mowers

- ▲ Riders obstruct the operator's view, they could be struck by foreign objects or thrown from the machine.
- ▲ Never allow children under 16 years of age to operate equipment.



### Use Seat Belt and ROPS

- ▲ Operate only mowers equipped with Roll-Over Protective Structure (ROPS) and seat belt.
- ▲ Fasten seat belt snugly and securely to help protect operator from being thrown, crushed, or severely injured if a rollover occurs; and from falling off the mower and being run over. Not using the seat belt & ROPS can result in serious injury or death.
- ▲ Wearing protective equipment such as safety shoes, safety glasses, hard hat, and ear plugs is highly recommended.
- ▲ **LOW STRUCTURES CAN FLIP MOWER OVER BACKWARDS.** Lower ROPS to drive under low structures such as tree limbs and doorways.



### Avoid High Pressure Fluids Hazard

- ▲ Escaping fluid under pressure can penetrate the skin causing serious injury.
- ▲ Avoid the hazard by relieving pressure before disconnecting hydraulic lines or performing work on the system.
- ▲ Make sure all hydraulic fluid connections are tight and all hydraulic hoses and lines are in good condition before applying pressure to the system.
- ▲ Use a piece of paper or cardboard, NOT BODY PARTS, to check for suspected leaks.
- ▲ Wear protective gloves and safety glasses or goggles when working with hydraulic systems.
- ▲ **DO NOT DELAY.** If an accident occurs, see a doctor familiar with this type of injury immediately. Any fluid injected into the skin or eyes must be treated within a few hours or gangrene may result.



These are common practices that may or may not be applicable to the products described in this manual.

### Practice Safe Maintenance

- ▲ Understand safe and correct maintenance procedures before doing work. Use proper tools and equipment, refer to Operator's Manual for additional information.
- ▲ Work in a clean dry area.
- ▲ Never run mower in an enclosed area. Mower engine exhaust emits carbon monoxide and other poisonous gases.
- ▲ Keep hands, feet, body extremities, and clothing away from all moving parts such as pulleys, belts, cutting blades, engine, and wheels. Don't wear loose fitting clothing while operating or servicing mower.
- ▲ Put mower in neutral, set park brake, disengage blades, turn off engine, remove switch key and wait for all moving components to stop before performing maintenance on the mower.
- ▲ Repairs or maintenance requiring engine power should be performed by trained personnel only.
- ▲ Allow mower to cool completely before performing maintenance.
- ▲ Disconnect battery ground cable (-) before servicing or adjusting electrical systems or welding on the mower.
- ▲ Observe safe fuel handling precautions. Fuel is flammable and vapors are very explosive.
- ▲ Do not grease or oil mower while in operation.
- ▲ Inspect all parts. Make sure parts are in good condition and installed properly.
- ▲ Remove buildup of grease, oil, or debris.
- ▲ Replace all guards and floor pan before putting mower back into service.
- ▲ Remove all tools and unused parts from mower before operation.



## Important Safety Information

### Safety Labels

Your Zero Turn Mower comes equipped with all safety labels in place. They were designed to help you safely operate your implement. Read and follow their directions.

1. Keep all safety labels clean and legible.
2. Refer to this section for proper label placement. Replace all damaged or missing labels. Order new labels from your nearest Land Pride dealer. To find your nearest dealer, visit our dealer locator at [www.landpride.com](http://www.landpride.com).
3. Some new equipment installed during repair requires safety labels to be affixed to the replaced component as

specified by Land Pride. When ordering new components make sure the correct safety labels are included in the request.

4. Refer to this section for proper label placement. To install new labels:
  - a. Clean surface area where label is to be placed.
  - b. Spray soapy water onto the cleaned area.
  - c. Peel backing from label and press label firmly onto the surface.
  - d. Squeeze out air bubbles with edge of a credit card or with a similar type of straight edge.

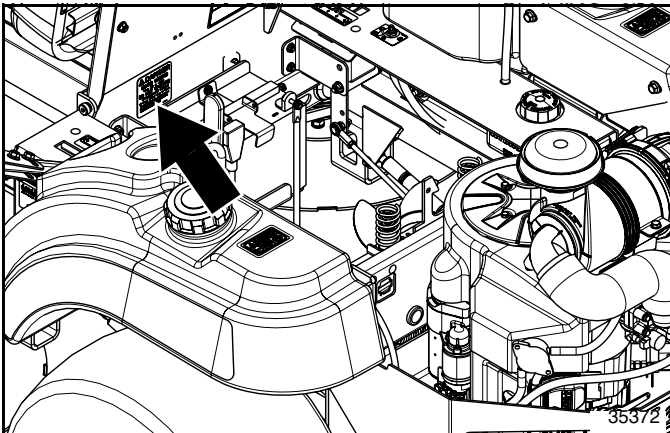

#### 818-543C

Danger: Guard Missing  
(Beneath Seat Platform)

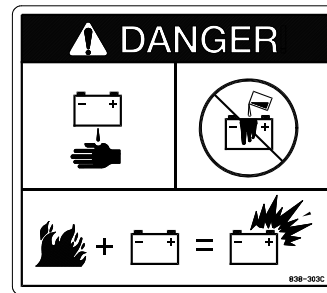
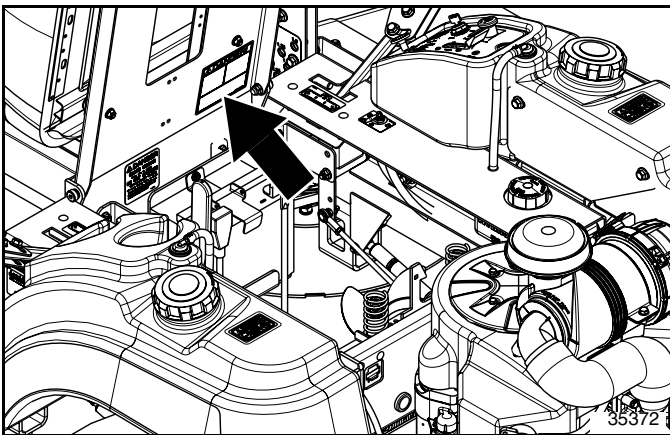

#### 838-303C

Danger: Battery  
(Beneath Seat Platform)

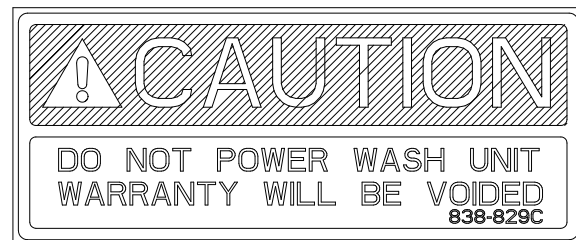
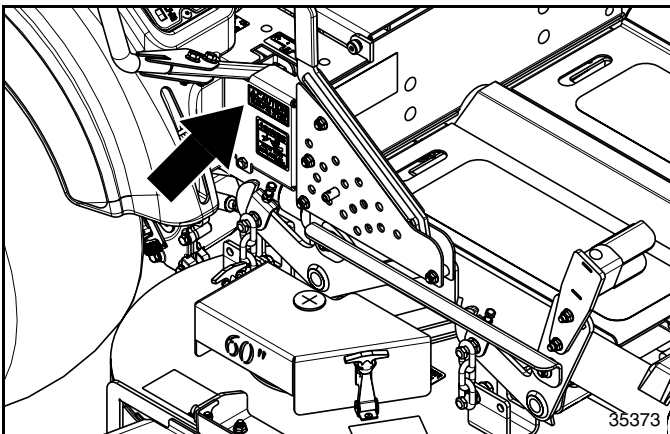

#### 838-829C

Caution: Do Not Power Wash

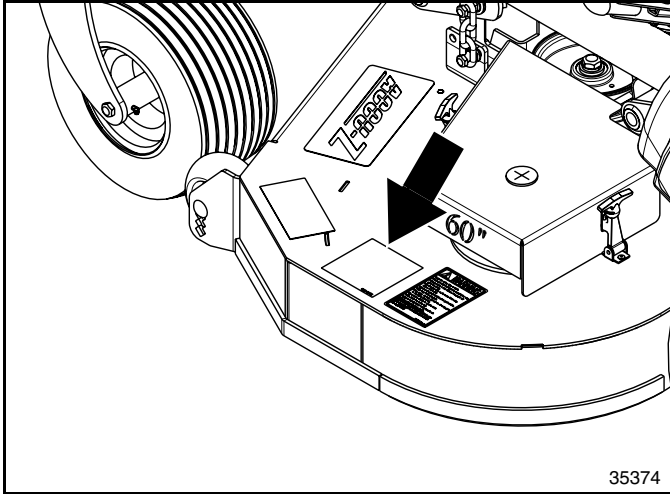

**838-307C**

Warning: Moving Parts

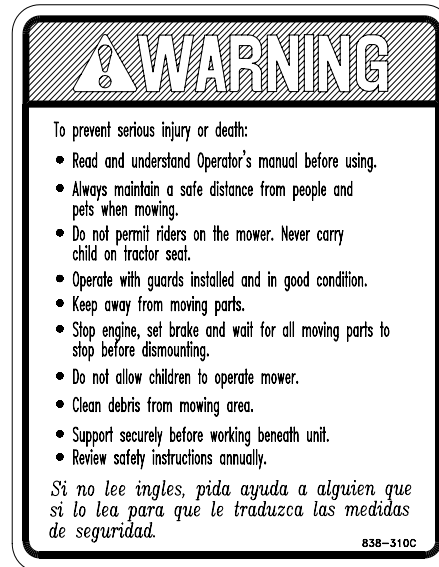
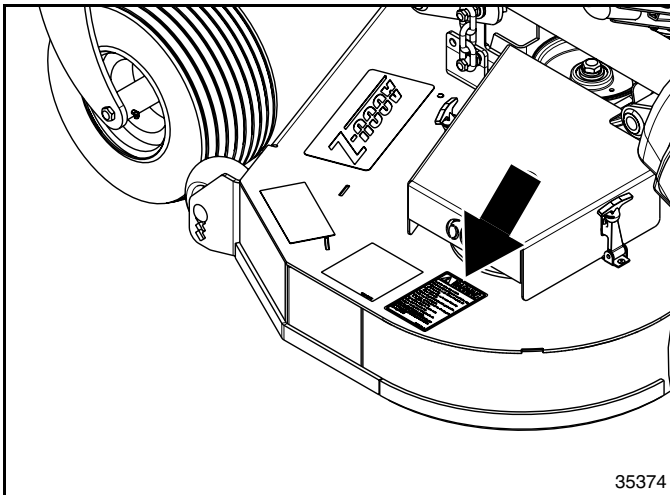

**838-310C**

Warning: General

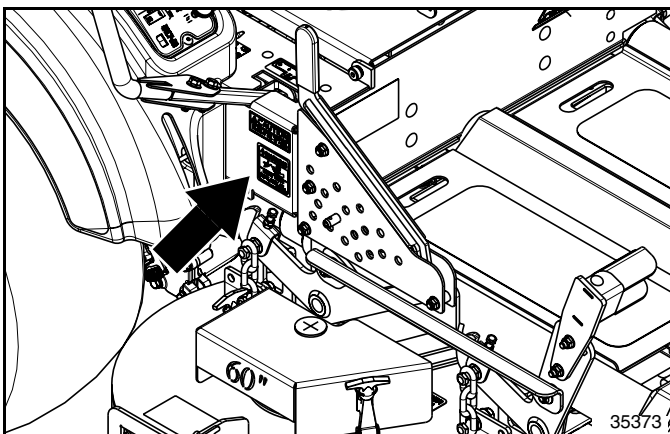

**838-815C**

Warning: Rollover Hazard

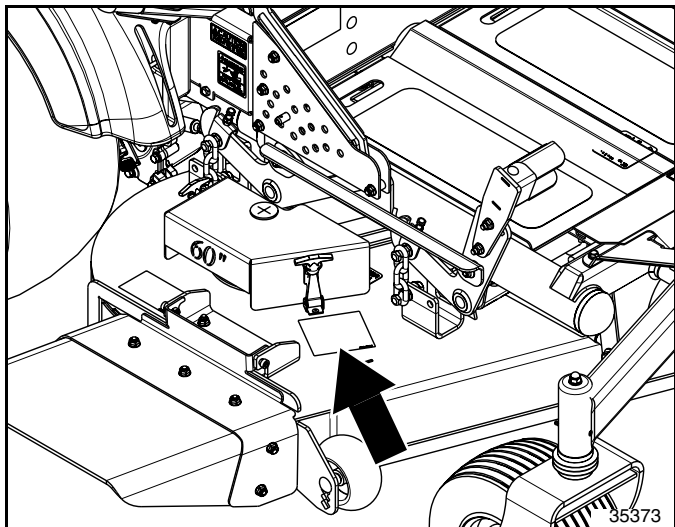

**! WARNING**

**ROTATING BLADE HAZARD**

- Keep Away - Rotating Blades
- To prevent serious injury or death from thrown object:
- Do not operate with deflectors removed.
- Do not point discharge toward people, animals or buildings when operating.
- Do not place hands or feet under deck when operating or when engine is running.

SW800

**838-308C**

Warning: Rotating Blade Hazard

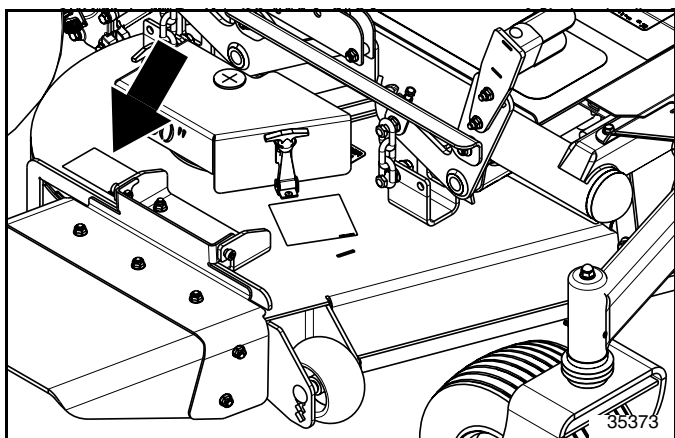

**! WARNING**

**THROWN OBJECT HAZARD  
KEEP AWAY**

- To prevent serious injury or death from thrown object
- Do not operate unless deflector is in place and in lowest position or complete grass collection system is in place.

838-306C REV.A

**838-306C**

Warning: Do not operator without deflector

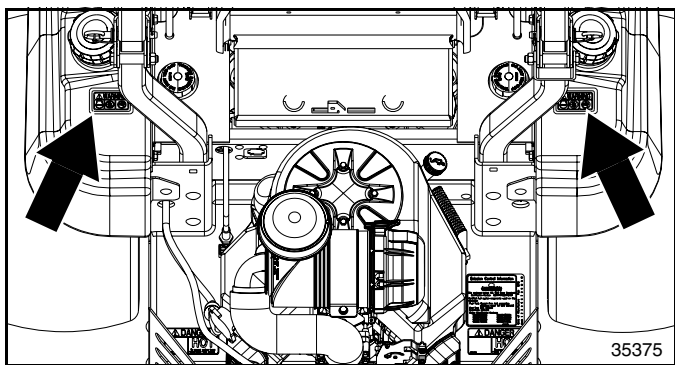

**! WARNING**

**838-833C**

Warning: Fuel (Imbedded in Fuel Tank)

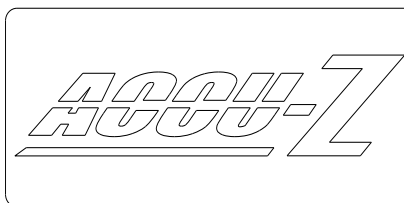
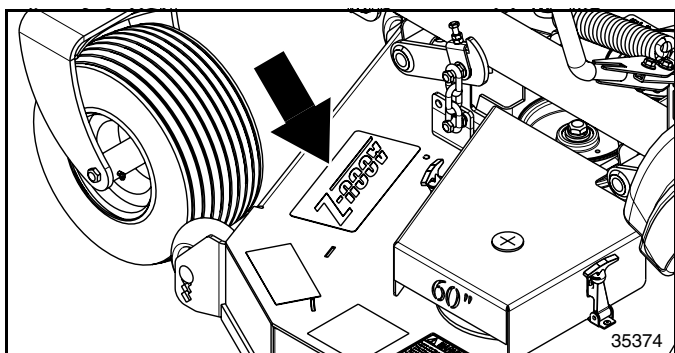

**840-335C**

Anti-slip step pad



Important Safety Information

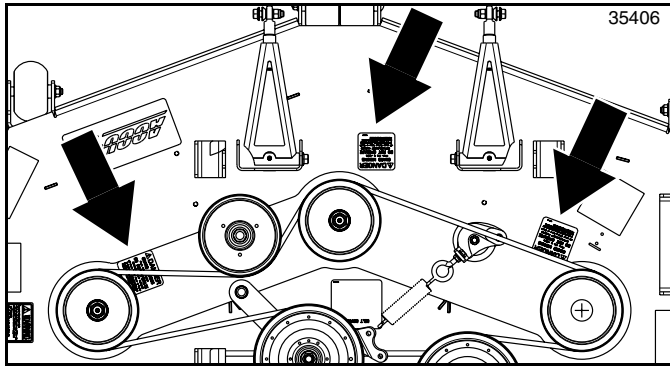

Beneath Pulley Shields

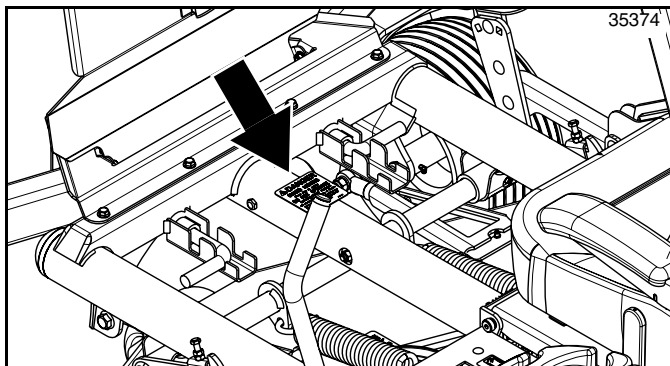

Beneath Floor Pan

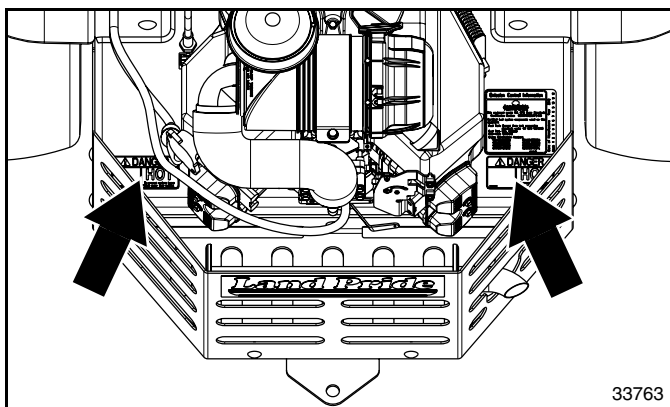
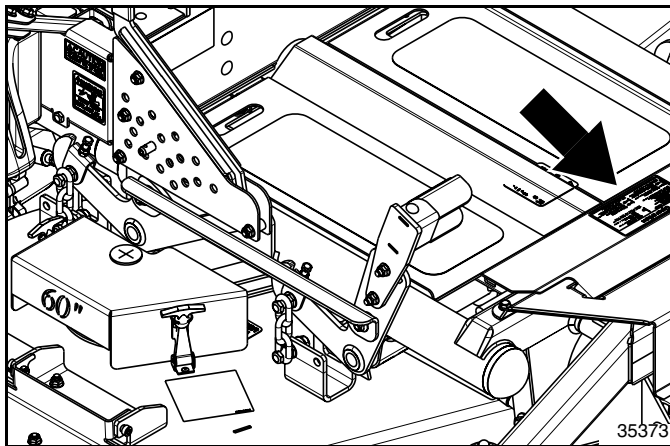

**! DANGER**

**GUARD MISSING**

When this is visible

**DO NOT OPERATE**

ENTANGLEMENT HAZARD

can cause Serious Injury or Death

*Si no entiende ingles, se prefiere que busque a alguien que interprete las instrucciones para usted.*

PHDC 6

**818-543C**

Danger: Guard Missing  
 3 - Places On The Deck  
 1 - Place Beneath Floor Pan

Operation

<p><b>Read Owner's Manual</b>                  Help Avoid Injury</p> <ul style="list-style-type: none"> <li>△ Operator training required.</li> <li>△ Know all controls.</li> <li>△ Keep shields in place.</li> <li>△ Maintain all safety devices.</li> <li>△ Look behind before backing.</li> <li>△ Keep children and others away.</li> <li>△ Stay clear of power driven parts.</li> <li>△ Do not operate where machine could tip.</li> </ul>	<p><b>While Operating</b></p> <ul style="list-style-type: none"> <li>△ Never perform maneuvers at high ground speeds.</li> <li>△ Avoid sudden turns.</li> <li>△ Avoid quick movements of steering levers.</li> <li>△ Reduce speed and use extreme caution when operating on slopes of 15 degrees or more.</li> </ul>
<p><b>Before Starting</b></p> <ul style="list-style-type: none"> <li>△ Steering levers must be in neutral position.</li> <li>△ Park brake must be in ON position.</li> <li>△ Deck clutch must be in OFF position.</li> <li>△ Check performance of all safety interlock switches daily (including operator presence switches).</li> </ul>	<p><b>Before Leaving Operating Platform</b></p> <ul style="list-style-type: none"> <li>△ Place steering levers in neutral position.</li> <li>△ Place park brake in ON position.</li> <li>△ Place deck clutch in OFF position.</li> <li>△ Turn engine OFF and remove key.</li> <li>△ Check machine when parked on slope.</li> </ul>

848-268C

**848-268C**

Warning: Safe Operating Instructions

**! DANGER**

838-444C

HOT

To prevent serious burns:  
 • Keep away from muffler.

**838-444C**

Danger: Muffler Hot  
 (Both Sides of Engine)



## Introduction

Land Pride welcomes you to the growing family of new product owners.

This mower has been designed with care and built by skilled workers using quality materials. Proper assembly, maintenance, and safe operating practices will help you get years of satisfactory use from this machine.

## Application

The Accu-Z ZT360 and ZT372 Zero Turn Mowers from Land Pride are commercial duty mowers. They are very maneuverable, extremely comfortable, highly productive, and come in cutting configurations designed to meet the needs of even the most discriminating owners and custom operators. This makes the ZT3 Series one of the premier choices of grass maintenance machines for ranchers, farmers, large estate owners, cemeteries, municipalities, campuses, and landscape maintenance contractors.

The ZT3 Series mowers come equipped with a choice of either 60" or 72" cutting decks with high blade tip speeds ranging from 18,350 feet per minute on the 60" deck to 19,300 feet per minute on the 72" deck. The decks adjust from 1" to 5" cutting height in 1/4" increments. The 60" deck meets the needs of customers who mow in tighter areas around obstacles or want to maintain a lower cutting height over undulating terrain. The more productive 72" cutting deck will meet the needs of customers with more level and open areas to cut and just want to get the mowing job done faster. The Accu-Z is supplied with 27 hp Kawasaki air cooled engines for proven performance, power, and reliability.

Customers living in areas with hills or warmer and wetter climates will typically want to employ the floating axle capability for enhanced traction capability and a smoother ride. Twin-lever hydrostatic steering will enable the Land Pride Accu-Z Zero Turn Mowers to turn within their overall length. Couple this outstanding maneuverability with a maximum 12 mph mowing speed and low center of gravity and you've got mowing capability that's fast, safe, comfortable, and easy to transport that will meet your commercial needs.

See "**Specifications & Capacities**" on page 53 and "**Features & Benefits**" on page 56 for additional information and performance enhancing options.

## Using This Manual

- This Operator's Manual is designed to help familiarize the operator with safety, assembly, operation, adjustments, troubleshooting, and maintenance. Read this manual and follow the recommendations to help ensure safe and efficient operation.
- The information contained within this manual was current at the time of printing. Some parts may change slightly to assure you of the best performance.
- To order a new Operator's or Parts Manual, contact your authorized dealer. Manuals can also be downloaded, free-of-charge, from our website at [www.landpride.com](http://www.landpride.com).

## Terminology

"Right" or "Left" as used in this manual is determined by facing forward while sitting in the operator seat unless otherwise stated.

## Definitions

**IMPORTANT:** A special point of information related to the following topic. Land Pride's intention is this information must be read & noted before continuing.

**NOTE:** A special point of information that the operator should be aware of before continuing.

## Owner Assistance

The Online Warranty Registration should be completed by the dealer at the time of purchase. This information is necessary to provide you with quality customer service.

The parts on your Zero Turn Mower have been specially designed by Land Pride and should only be replaced with genuine Land Pride parts. Contact a Land Pride dealer if customer service or repair parts are required. Your Land Pride dealer has trained personnel, repair parts, and equipment needed to service the implement.

For parts and service to your mower engine, contact your nearest engine dealer or call Customer Service Hotline provided below.

Owner's Manual Part No.	
Kawasaki - 27 HP . . . . .	99920-2232
Service Manual Part No.	
Kawasaki - 27 HP . . . . .	99924-2089-01
Service Hotline Phone No.	
Kawasaki . . . . .	1-800-433-5640

## Serial Number

Model No. \_\_\_\_\_ Serial No. \_\_\_\_\_

For quick reference and prompt service, record model number and serial number in the spaces provided above and again on warranty page 62. Always provide model number and serial number when ordering parts and in all correspondences with your Land Pride dealer. Refer to Figure 1 on page 9 for location of your serial number plate.

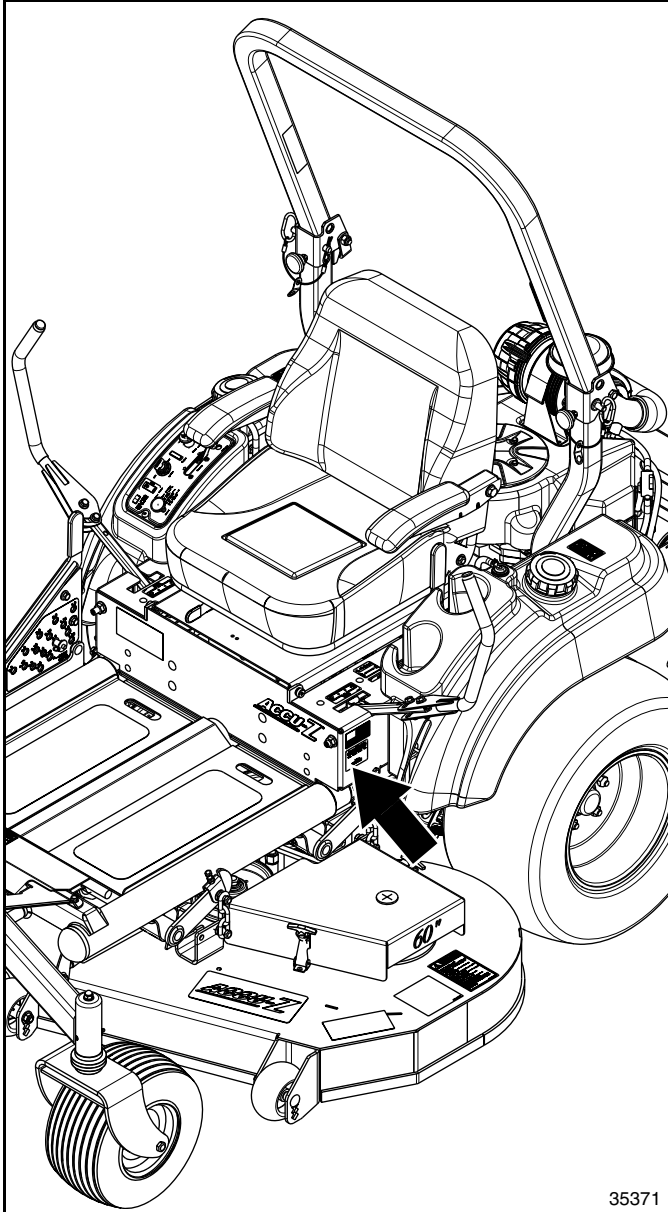

35371

**Serial Number Plate Location  
Figure 1**

**Further Assistance**

Your dealer wants you to be satisfied with your new mower. If for any reason you do not understand any part of this manual or are not satisfied with the service received, the following actions are suggested:

1. Discuss the matter with your dealership service manager making sure that person is aware of any problems you may have and has had the opportunity to assist you.
2. If you are still not satisfied, seek out the owner or general manager of the dealership, explain the problem, and request assistance.
3. For further assistance write to:

**Land Pride Service Department**  
**1525 East North Street**  
 P.O. Box 5060  
 Salina, Ks. 67402-5060  
 E-mail address  
 lpservicedept@landpride.com

## Section 1: Assembly & Set-up

### Uncrating Instructions

The shipping crate is assembled together with nails. It can be disassembled by prying or cutting the lumber apart. Be careful not to scratch, dent, or cut the mower and seat while uncrating. It is best if two people are present while disassembling the crate.

1. Remove end and side panels from shipping crate.

**IMPORTANT:** Do not drive mower off the crate floor, as this can bend or break components underneath the mower, especially the transaxles. Lift mower off the crate floor with a hoist or other suitable lifting device. Be careful not to damage the paint and seat while lifting the unit off the crate floor.

2. Gently lift mower from crate floor with a hoist or other suitable lifting device.

### Torque Requirements

Refer to “**Torque Values Chart**” on page 60 to determine correct torque values for common bolts. See “**Additional Torque Values**” at bottom of chart for exceptions to standard torque values.

### Control Lever Assembly

Refer to **Figure 1-1:**

Control levers (#2 & #3) are factory shipped rotated down and secured with control lever mounting bolts (#7A).

1. Loosen bolt (#7A) on upper right control lever (#3).
2. Remove bolt (#7B) from lower right control lever (#4).
3. Rotate control lever up until slot in upper control lever aligns with hole in lower control lever.
4. Reinstall 3/8"-16 1 1/2" GR5 hex head bolt (#7B) and 3/8" hex flange lock nut (#9).
5. Repeat steps 1 to 4 for left control lever (#2).
6. Align control lever handles with each other and tighten bolts (#7A & #7B) to the correct torque.

**NOTE:** To make final control lever adjustments, see “**Upper Control Lever**” on page 27.

### Seat Assembly

Refer to **Figure 1-1:**

Depending on seat option, the mower may be shipped with seat attached. If not, the seat (#1) is shipped factory mounted to the hinged seat platform (#4) and attached to the shipping crate with lag bolts. It may have already been removed in step 1 under “**Uncrating Instructions**”. If not, remove it now.

**IMPORTANT:** Be careful not to cut seat material when removing protective packing around the seat. **Cutting seat material will void its warranty.**

1. Spread control levers (#2 & #3) fully apart before attaching seat platform to mower frame.

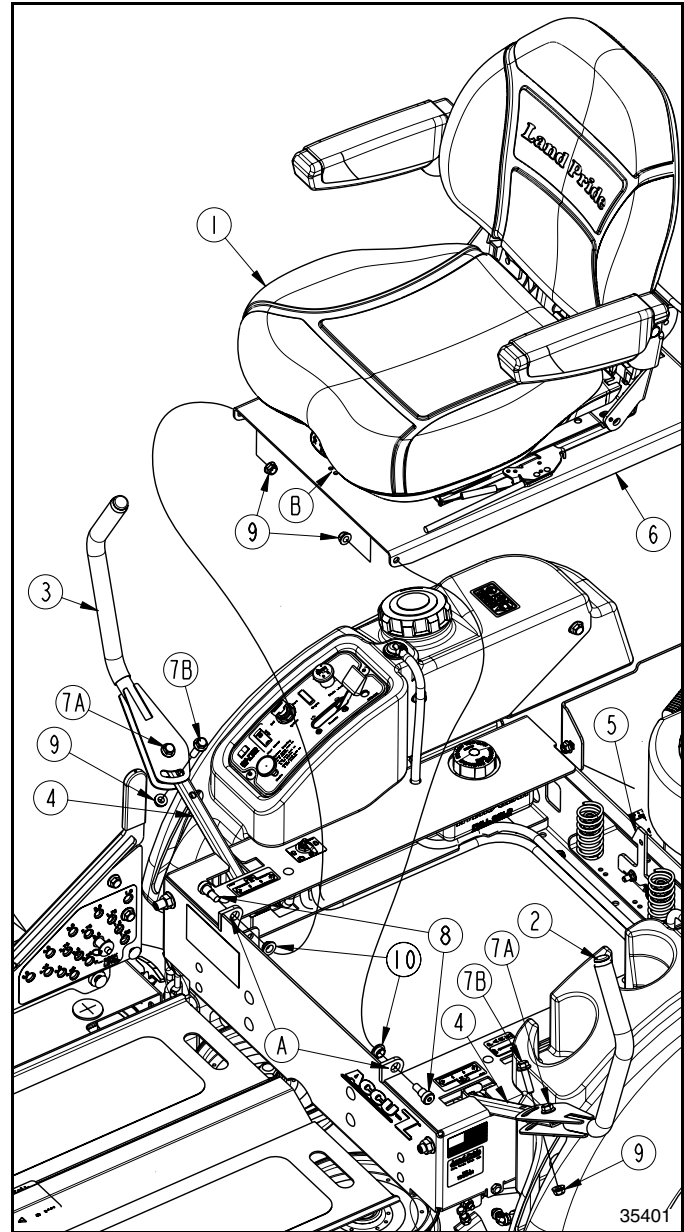

**Control Lever & Seat Assembly (Standard Seat Shown)**  
**Figure 1-1**

2. Insert flange bushing (#10) into holes “A” as shown.
3. Attach seat platform (#6) with 3/8"-16 shoulder bolts (#8) and hex flange lock nuts (#9) as shown. Tighten lock nuts to the correct torque.
4. Connect mower switch wires to the seat switch located under the seat.
5. Zip tie wire for seat switch to seat pan using holes “B”.
6. Hinge seat platform down. The platform will catch automatically under the spring loaded latch (#5).
7. Being careful not to cut seat material, remove protective packing around seat.
8. See “**Seat Reach Adjustment**” on page 25 for positioning the seat forward and rearward.

## Section 1: Assembly & Set-up

### Spring Loaded Seat Release Latch

Refer to Figure 1-2:

#### **WARNING**

The seat pan should always be latched in the down position before starting mower. Not doing so can cause bodily injury.

When seat is shipped attached to the mower, the spring loaded seat release latch (#3) is bolted shut for shipping purposes only. Bolt (#1) and nut (#2) should be removed during dealer set-up.

1. Remove hex flange nut (#2) and carriage bolt (#1) from seat release latch (#3).
2. Discard carriage bolt and hex flange nut.
3. See “**Accessing Area Beneath Seat Platform**” on page 16 for special step by step instructions on accessing the area below the seat platform.

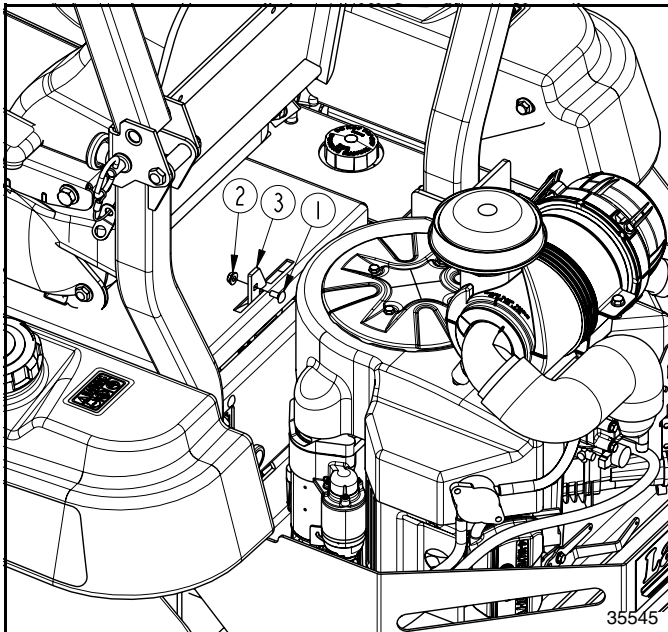

**Seat Release Latch**  
Figure 1-2

### Discharge Chute Assembly

Refer to Figure 1-3:

The Zero Turn Mower is shipped with carriage bolts (#2) and hex flange locknuts (#3) attached to the deck in the location shown. Remove carriage bolts from deck and attach discharge chute to the deck as follows:

1. Attach discharge chute (#1) to the deck by inserting 3/8"-16 x 1" GR5 carriage bolts (#2) up through deck bottom as shown.
2. Secure with hex flange locknuts (#3). Tighten lock nuts to correct torque.

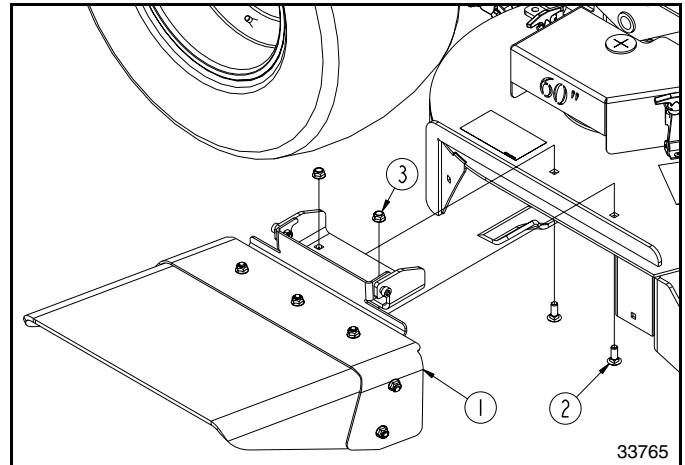

**Discharge Chute Assembly**  
Figure 1-3

## Section 1: Assembly & Set-up

### Folding ROPS

#### **! DANGER**

Low structures can make contact with the ROPS and flip the mower over backwards. Fold ROPS down when driving under low structures such as tree limbs and doorways.

#### **! CAUTION**

Keep hands and other body extremities away from hinged pinch points while folding and unfolding ROPS.

The ROPS (Roll Over Protection System) is shipped factory installed and folded down.

### ROPS Unfolding Instructions

Refer to Figure 1-4:

ROPS locking knobs (#1) are shipped in an attached parts bag.

1. Remove hitch pins (#2) and rotate upper ROPS frame (#3) up to position shown.
2. Reinsert hitch pins (#2) and secure with attached hairpins.
3. Install locking knobs (#1) and hand tighten.

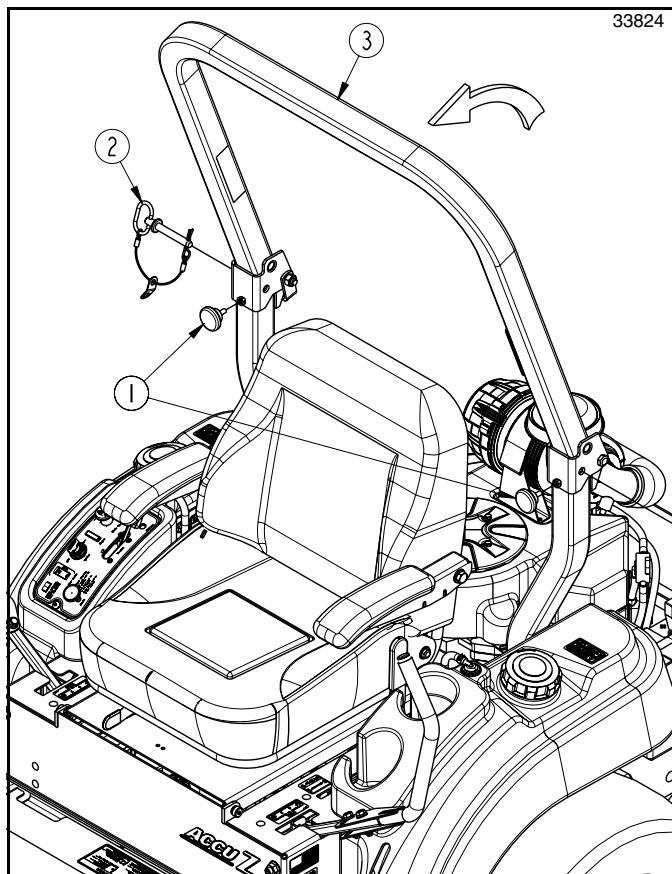

Folding ROPS Bar Assembly  
Figure 1-4

### Electrical Cable Connection

Refer to Figure 1-5:

#### **! WARNING**

Incorrect battery cable connections can damage the mower's electrical system and cause battery cables to spark. Sparks around a battery can result in a battery gas explosion and personal injury.

- Always disconnect negative (black) cable from battery before disconnecting positive (red) cable.
- Always reconnect positive (red) cable to the battery's positive (+) post before reconnecting negative (black) cable to the battery's negative (-) post.

#### **! WARNING**

Keep battery terminals from touching any metal mower parts when removing or installing battery. Do not allow metal tools to short between battery terminals and metal mower parts. Shorts caused by battery terminals or metal tools touching metal mower components can cause sparks. Sparks can cause a battery gas explosion which can result in personal injury.

**IMPORTANT:** The black negative battery cable is disconnected before leaving the factory and is to be disconnected after initial dealer set-up to prevent battery discharge while sitting on the dealer lot.

Attach black battery cable (#3) to the negative post with 1/4"-20 x 3/4" GR5 serrated screw (#1) and hex whiz nut (#2). Tighten whiz nut to the correct torque.

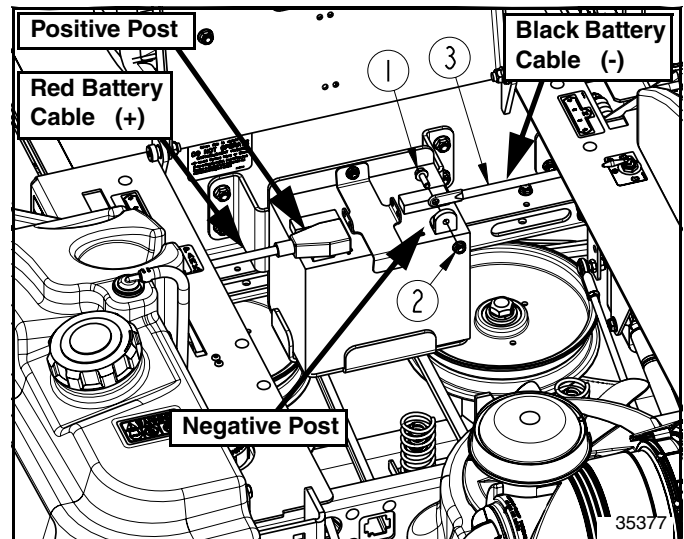

Connecting Black Cable To Negative Battery Post  
Figure 1-5

### Engine Preparations

1. Check engine oil level at the dipstick. Add oil if below full mark. **Do not overfill.** Refer to Engine Operator's Manual for oil recommendation and to "**Engine Oil & Oil Filter**" on page 44 in this manual.

**NOTE:** Mowers are shipped from the factory without fuel in the fuel tanks.

2. First read instructions under "**Fuel System**" on page 42 and then add a small amount of gasoline with fuel stabilizer to the fuel tank.

Section 2: Operating Procedures

Mower Features

Refer to Figure 2-1:

Your Zero Turn Mower is designed with innovative and state-of-the-art features. Knowing the location and how these features work will make handling your mower more

comfortable. Below is a list of major features to be reviewed in this section. Not all features listed will be reviewed.

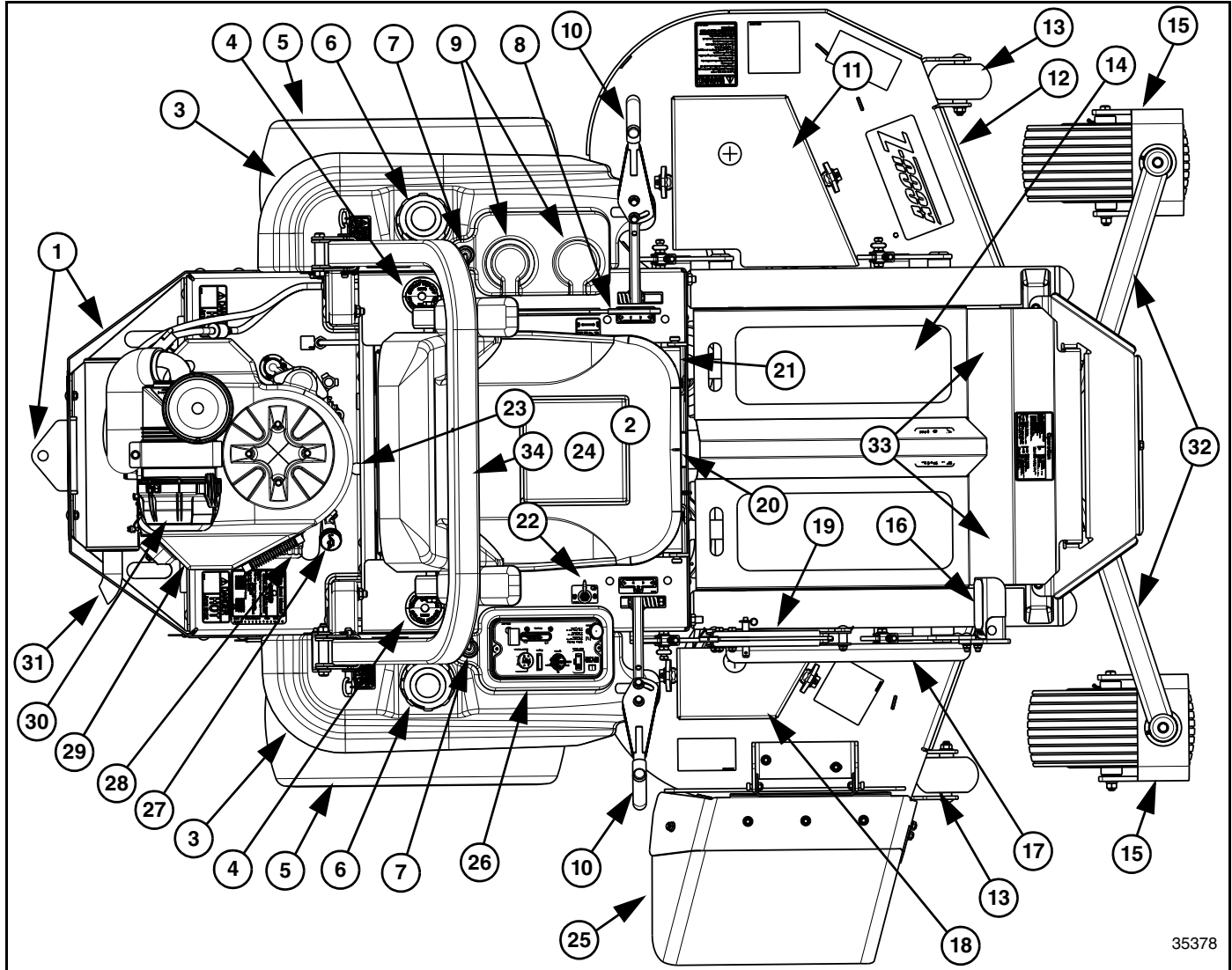

35378

- |  |  |  |
|--|--|--|
| 1. Rear Bumper, Hitch & Engine Guard     | 14. Floor Pan (Guard)                                | 26. Control Panel<br>(See Figure 2-2 on page 15)               |
| 2. Battery (Located under seat platform) | 15. Caster Wheels                                    | 27. Oil Fill / Dip Stick                                       |
| 3. Fuel Tanks                            | 16. Adjustable Deck Lift Pedal                       | 28. Oil Filter   |
| 4. Hydraulic Oil Expansion Tank Caps     | 17. Deck Height Gauge Bar                            | 29. Gas Engine   |
| 5. Drive Wheels                          | 18. Right Deck Spindle Cover (Guard)                 | 30. Engine Air filter  |
| 6. Tethered Fuel Caps                    | 19. Deck Height Indicator                            | 31. Engine Exhaust Muffler                                     |
| 7. Fuel Vent Valves                      | 20. Operator Seat                                    | 32. Front Floating Axle  |
| 8. Cup Holders                           | 21. Seat Platform (Guard)                            | 33. Floating Axle Locks (Bent Pins<br>located under floor pan) |
| 9. Park Brake Lever                      | 22. Left/Right Fuel Tank Select Switch               | 34. ROPS, Roll Over Protective Structure                       |
| 10. Control Levers                       | 23. Seat Release Latch (Behind Seat)                 |  |
| 11. Left Deck Spindle Cover (Guard)      | 24. Operator Pressure Switch<br>(Located under seat) |  |
| 12. 60" or 72" Mower Deck                | 25. Discharge Chute (Guard)                          |  |
| 13. Anti-Scalp Wheels                    |  |  |

ZST Mower Features (ZT360 Shown)  
Figure 2-1



Section 2: Operating Procedures

**Operating Checklist**

Hazard control and accident prevention are dependent upon awareness, concern, prudence and proper training involved in operation, transport, maintenance, and storage of the riding mower. Therefore, it is absolutely essential that no one operates the mower without first having read, fully understood, and become totally familiar with the Operator's Manual. Make sure the operator has paid particular attention to:

- **Important Safety Information**, page 1
- **Section 1: Assembly & Set-up**, page 10
- **Section 2: Operating Procedures**, page 14
- **Section 3: Adjustments**, page 24
- **Section 5: Maintenance & Lubrication**, page 34

The following Operating Checklist should be performed before operating your mower:

**Operating Checklist**

✓	Check	Ref.
	Carefully read and follow all safety rules. Refer to "Important Safety Information".	Page 1
	Make sure all guards and shields are in place. Refer to "Mower Features".	Page 14
	Make all required adjustments. Refer to "Section 3: Adjustments".	Page 24
	Read and follow all operating procedures. Refer to "Section 2: Operating Procedures".	Page 14
	Check mower safety start interlock system daily prior to operation.	Page 19
	Perform all maintenance and lubrications. Refer to "Section 5: Maintenance & Lubrication".	Page 34
	Make sure there are no hydraulic leaks on the unit. Refer to "Avoid High Pressure Fluids Hazard".	Page 2
	Check blade for nicks and sharpness. Refer to "Mower Blade Maintenance".	Page 47
	Check mower initially and periodically for loose bolts and pins. Refer to "Torque Values Chart".	Page 60

**Control Panel**

Refer to Figure 2-2:



**WARNING**

Do not operate mower while smoking.

**Ignition Switch**

A three position ignition switch: off, run, and start is provided. With key inserted, rotate it clockwise to **START** position; release key when engine starts and switch will automatically return to **RUN** position. Turn key counterclockwise to **OFF** position to stop engine.

**Throttle**

A cable is linked from engine to throttle for controlling engine speed. Move throttle lever toward fast position to increase engine rpm and toward slow position to decrease rpm. Always travel and cut grass with throttle set at full engine rpm speed. Decrease travel speed by

pulling back on the control levers. Reduce engine rpm only when mower is not traveling and just before engaging the cutting blades.

**IMPORTANT:** Always operate throttle at full engine rpm while traveling and cutting grass. Operating engine at a slow rpm may overheat engine and transaxles.

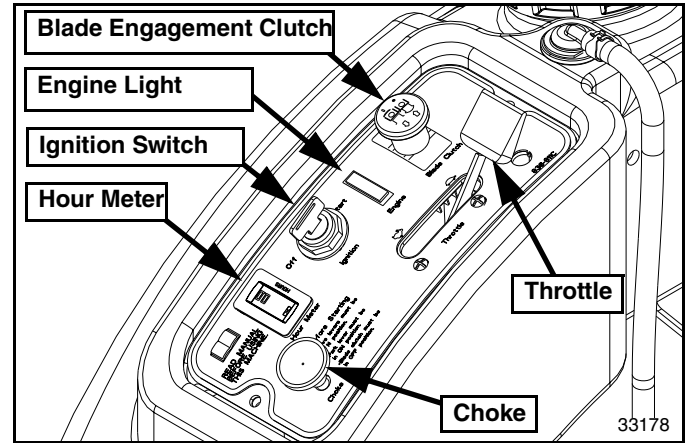

**Control Panel**  
**Figure 2-2**

**Choke**

A cable is linked from the choke control knob to the engine for choking the engine during starting. Pull up on knob to turn choke (**ON**). Push down on knob once engine is running to shut choke (**OFF**).

**IMPORTANT: DO NOT** operate mower with choke on.

**Blade Engagement Switch**

The blade engagement switch engages the deck blades. Pull switch up (**ON**) to engage blades and push switch down (**OFF**) to disengage blades.

**IMPORTANT:** With mower stopped and engine at half throttle, engage cutting blades. Increase throttle to full engine speed and then operate control levers to move mower. Clutch, belts and/or deck may be damaged if blades are engaged at full engine speed.

**Hour Meter**

The hour meter registers 1/10 hour increments up to 9,999.9 total hours. The meter is connected to the ignition switch and records accumulative time only while the engine is running. Remove plastic film covering over hour meter before placing mower into service.

**Engine Light**

The engine light, when lit, indicates low oil pressure. This light will come on when starting engine and should go off soon after engine is started. Shut engine off immediately if light comes on during normal operation and investigate cause before putting mower back into service.

## Section 2: Operating Procedures

### Park Brake

Refer to Figure 2-3 & Figure 2-4:

The park brake lever is linked to the wheel motors. The rear wheels are kept from turning when park brake lever is pulled back or to the **(ON)** position. Push lever forward to **(OFF)** position to release park brakes.

Mower engine will stop running if park brake lever is set to **(ON)** before spreading both control levers **(OUT)** or if one or both control levers are moved **(IN)** before moving park brake lever to **(OFF)**.

### Control Levers

Refer to Figure 2-3 & Figure 2-4:

The control levers are used to steer, accelerate, decelerate, stop, and change direction of travel.

Always move both control levers to neutral position and then spread them fully **(OUT)** before setting park brake lever to the **(ON)** position. Set park brake to the **(ON)** position. Always leave park brake and control levers in this position until ready to start traveling. Move park brake to the **(OFF)** position before pulling control levers **(IN)**. Start moving by moving control levers either forward or rearward from neutral position.

See “Driving the Mower” on page 19 for a detailed description of operating the control levers.

### Accessing Area Beneath Seat Platform

Refer to Figure 2-5:

The compartment below the seat platform (#2) is where the control lever linkages, hydrostatic drives, belts, battery, and fuses are located. The seat is secured over this compartment with a spring loaded seat latch (#1).

**NOTE:** A carriage bolt may be inserted through square hole in latch (#1) and secured with a nut. Torque nut tight to prevent people from easily lifting the seat platform while mower is operating.

### WARNING

The seat pan should always be latched in the down position before starting mower. Not doing so can cause bodily injury.

Refer to Figure 2-3:

1. Park unit on a flat level surface. Stop engine and remove ignition key. Make sure blade engagement switch is **in the down (OFF) position**. Spread control levers fully apart and set park brake.

Refer to Figure 2-5:

2. Pull seat latch (#1) to the left & lift seat platform (#2) up to raise seat for viewing compartment below.
3. Close seat platform by lowering platform down until seat latch catches on the seat platform. See “Seat Reach Adjustment” on page 25 for positioning seat forward and rearward.

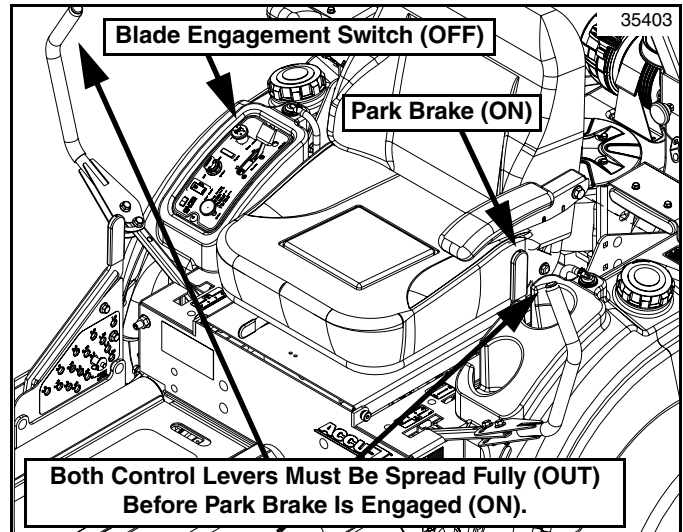

Control Levers Fully OUT (In Park Position)  
Figure 2-3

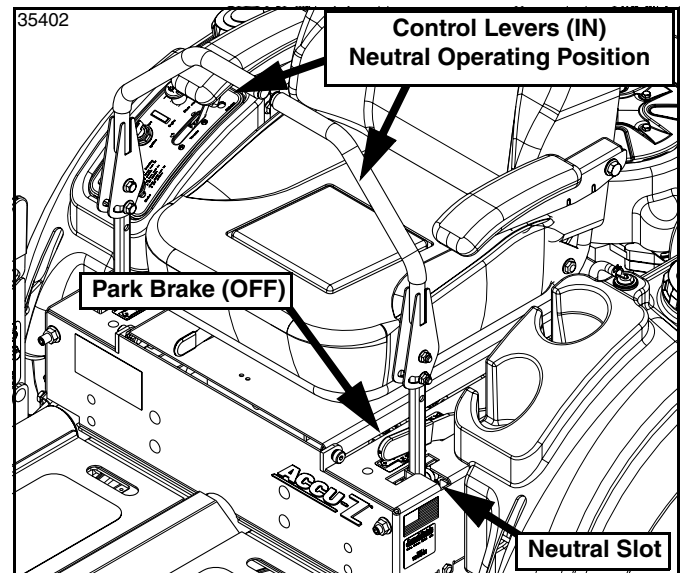

Control Levers Fully IN (In Neutral Position)  
Figure 2-4

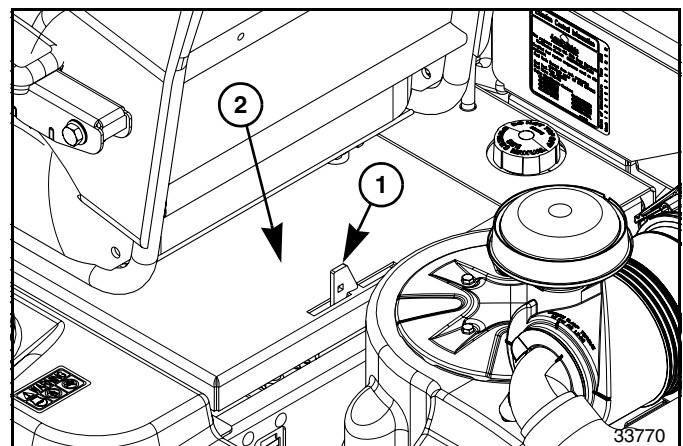

Seat Release Latch  
Figure 2-5

## Section 2: Operating Procedures

### Accessing Area Beneath Floor Pan

Refer to Figure 5-2:

Deck components located under the floor pan (#2) can be accessed easily by raising the floor pan up.

#### **WARNING**

The floor pan must always be in the down position before starting the mower. Not doing so can cause bodily injury.

1. Park unit on a flat, level surface. Stop engine and remove ignition key. Make sure blade engagement switch is in the down (**OFF**) position, control levers are spread **fully apart**, and park brake is pulled back to the (**ON**) position.
2. Rotate deck lift pedal (#1) rearward as shown.
3. Using hand holds in floor pan, raise floor pan (#2) up until resting on its front face as shown.
4. When finished working, lower floor pan down using hand holds and rotate deck lift pedal (#1) forward to normal operating position.

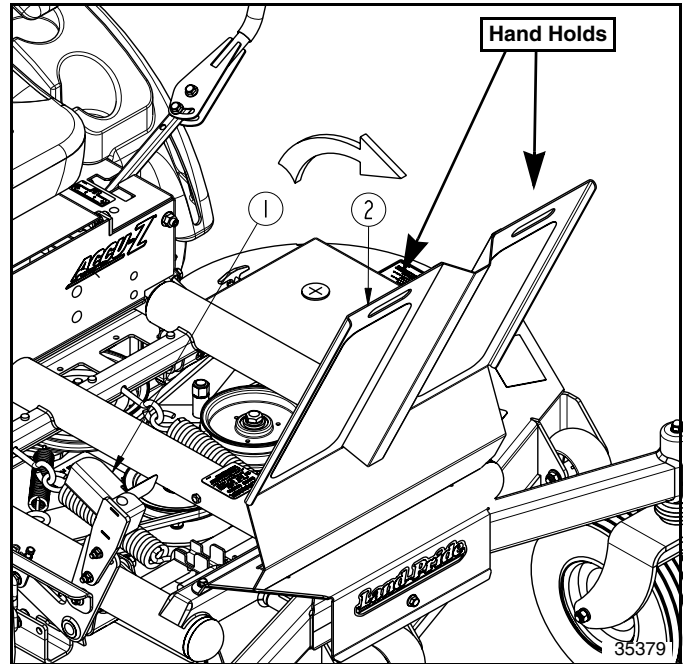

Hinge Floor Pan  
Figure 2-6

### Moving Mower with Stalled Engine

Refer to Figure 2-7:

Each hydro-drive is equipped with a bypass valve for the purpose of moving the mower when engine is inoperable. Both bypass valves are located under the hydro-drive cooling fan. They face toward the center of the mower in the location shown.

1. Rotate bypass valve slot to vertical (Bypass) position to allow drive wheel to rotate freely.
2. Repeat step 1 for the other hydro-drive.
3. Position both control levers in neutral with handles fully apart.
4. Release park brake lever.
5. Manually move mower by hand or with a winch.

**IMPORTANT:** Do not tow mower. Move it by hand or use a winch and load it onto a trailer. Make certain mower is properly secured to the trailer and its park brake is locked.

**IMPORTANT:** Following repairs, always make certain both bypass valves are rotated horizontal (run position) before operating mower.

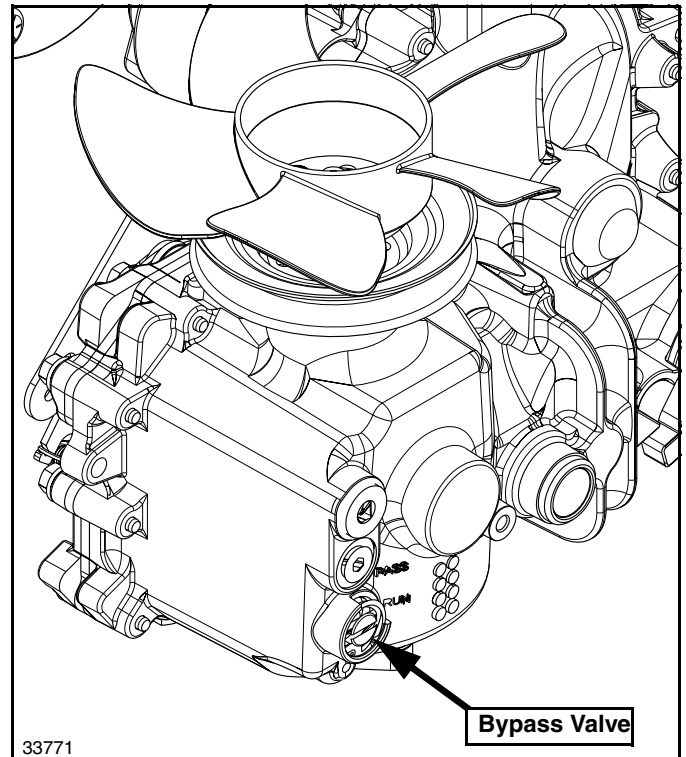

Bypass Valve (Operating or Run Position Shown)  
Figure 2-7

## Section 2: Operating Procedures

### Transport Height

Refer to Figure 2-8:

#### CAUTION

Disengage mower blades before changing deck height! Deck stop pin could get into rotating parts if dropped.

1. Disengage blades, move control levers fully out, and set park brake.
2. Push forward on deck lift pedal (#1) with your right foot to raise deck fully up until transport lock (#2) catches and holds deck up. Release deck lift pedal.

### Cutting Height

Refer to Figure 2-8:

**IMPORTANT:** The deck must be level and blades disengaged before setting deck cutting height. See instructions for “**Deck Leveling**” on page 28.

**IMPORTANT:** See deck stop (#3) in Figure 2-8. To operate deck stop pin, push in center button on head of pin to remove & insert pin.

**NOTE:** Cutting height provided on deck height indicator (#4) is from 1" to 5" in 1/4" increments.

1. Set deck at transport height. See “**Transport Height**” instructions above.
2. Push center button on head of deck stop pin (#3) and insert pin into desired cutting height pin hole on cutting height indicator (#4).
3. Push forward on deck lift pedal (#1) with your right foot, pull back on transport lock handle (#2), and slowly release deck lift pedal to gently lower deck against deck stop pin (#3).

### Clearing Obstacles

**IMPORTANT:** It is best to mow around obstructions; not over them. Beware, the front of the deck can clear an obstacle and still make contact by high centering on the obstacle. Mowing over obstacles that make contact with the deck can bend/break mower deck, mower blades, and blade spindles.

1. If it is necessary to drive over an obstruction, stop mower, turn off blades, and raise deck fully up to transport position.
2. Move forward slowly to make certain deck clears the obstruction.
3. Lower deck to cutting height after mower has passed over obstruction, engage blades, and continue mowing.

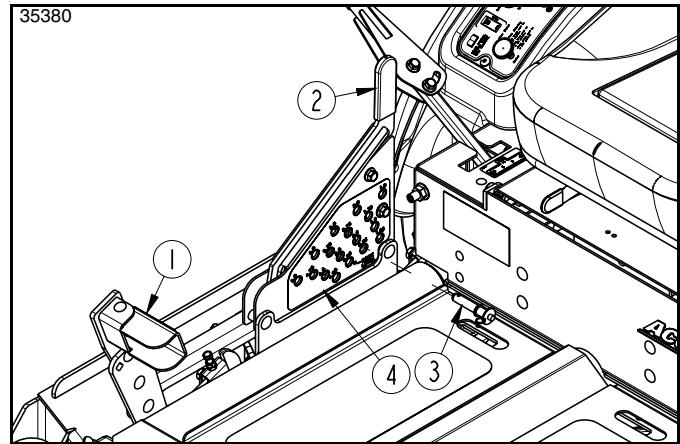

Deck Lift Pedal  
Figure 2-8

### Engine Starting

The safety start interlock system is designed to prevent runaway or accidental entanglement.

**IMPORTANT:** The starter motor will engage only if blade engagement switch is **(OFF)**, control levers are **(OUT)**, and park brake is **(ON)**.

The following steps are correct procedures for starting the engine. If difficulty is encountered, contact your local Land Pride dealer.

1. Before starting engine, make sure:
  - a. Blade engagement switch is **(OFF)**.
  - b. Both control levers are positioned **(OUT)**.
  - c. Park brake is **(ON)**.
2. Set speed control to approximately 1/2 open throttle.

**IMPORTANT:** Use choke when engine is cold or if warm and engine fails to start after 5 seconds of cranking. Avoid engine flooding by pushing choke control knob to **(OFF)** as soon as possible.

**IMPORTANT:** The engine starter should not be operated for periods longer than 30 seconds at a time. An interval of at least two minutes should be allowed between such cranking periods to protect the starter from overheating and burn-out.

3. Insert key into ignition switch and rotate clockwise to engage starter motor. Release key when engine starts.
4. Perform test to make sure safety start interlock system is operating properly. Refer to “**Safety Start Interlock System**” on page 19.
5. As soon as engine begins to run, check to make certain oil warning light is off. If not, stop engine immediately, and check for the cause. Refer to “**Troubleshooting**” on page 58.
6. Allow engine to idle a few minutes to warm up before operating the mower.

## Section 2: Operating Procedures

### Engine Shut-Down Sequence

It is always best to go through proper shut-down sequence before turning ignition switch key off. Not following this sequence in the correct order will cause the engine to stop running immediately.

1. Shut blade engagement switch (**OFF**).
2. Move both control levers to neutral and (**OUT**).
3. Throttle engine back to a low idle and wait for one minute to allow accumulated raw fuel to escape muffler during engine slow down.
4. Move park brake to the (**ON**) position.
5. Rotate ignition key counter-clockwise to (**OFF**) and remove from ignition switch.

### Safety Start Interlock System



#### WARNING

*Do not bypass any safety switch. Bypassing a safety switch can result in a serious injury or death.*

The mower is equipped with a safety start interlock system consisting of blade engagement switch, seat switch, park brake switch, and control lever switches. This system is an important safety feature designed to prevent runaway or accidental entanglement.

**IMPORTANT:** The starter motor will engage only if blade engagement switch is (**OFF**), control levers are (**OUT**), , and park brake is (**ON**).

Only after operator is seated and mower has been started can park brake be moved to (**OFF**) and control levers (**IN**) in that order or the engine will stop running. The blade engagement switch can be pulled (**ON**) only after park brake is moved to (**OFF**).

Park brake positioned (**ON**) or (**OFF**) does not stop engine when becoming unseated with both control levers (**OUT**) and blade engagement switch (**OFF**).

The safety start interlock system should be checked daily prior to operation and repaired immediately if it malfunctions. Inspect system as follows:

**IMPORTANT:** The operator must be on the seat when testing switches. Contact your local Land Pride dealer if the problem cannot be resolved.

1. Start mower engine per instructions in the section on “**Engine Starting**” on page 18. Allow engine to warm up to operating temperature.
2. With blade engagement switch (**OFF**), control levers spread fully (**OUT**), and park brake (**ON**), slowly raise off the seat. The engine should continue to run.

### Blade Engagement Switch

1. With engine running and operator sitting on the seat, move park brake to (**OFF**), pull both control levers (**IN**), and then turn blade engagement switch (**ON**).

2. Replace blade engagement switch if blades did not run and no other cause such as damaged wiring can be determined.

### Seat Switch

1. With engine running, park brake to (**OFF**), control levers (**IN**), and blade engagement switch (**ON**), slowly raise off the seat. The engine should stop within five seconds.
2. Replace seat safety switch if switch did not operate properly and if no other cause can be determined.

### Park Brake Switch

1. Turn blade engagement switch (**OFF**) and move control levers (**OUT**). Park brake must be (**OFF**).
2. Try restarting engine. Starter motor should not turn.
3. Replace park brake switch if starter motor did turn and no other cause can be determined.

### Control Lever Switches

1. With blade engagement switch (**OFF**), control levers fully (**OUT**), and park brake (**ON**), restart engine.
2. With park brake (**ON**) and blade engagement switch (**OFF**), pull right control lever in. The engine should stop within five seconds.
3. Replace right control lever switch if switch failed to operate properly and no other cause can be determined.
4. Return right control lever to original setting and restart engine.
5. With park brake (**ON**) and blade engagement switch (**OFF**), pull left control lever in. The engine should stop within five seconds.
6. Replace left control lever switch if switch did not operate properly and no other cause can be determined.

### Driving the Mower



#### DANGER

*Never make sudden stops or sudden reversing of travel direction, especially when going down a slope. The steering is designed for sensitive response. Rapid movement of control levers could result in a reaction that can cause serious injury.*



#### DANGER

*Never make sudden speed changes from reverse to forward. Always push control levers forward gently to avoid sudden change in speed. Any sudden forward speed change can cause the front wheels to raise off the ground resulting in loss of control, mower damage and/or personal injury.*

**NOTE:** When turning on soft wet turf, keep both wheels rolling either forward or backward. Pivoting on a stopped wheel can damage the turf.

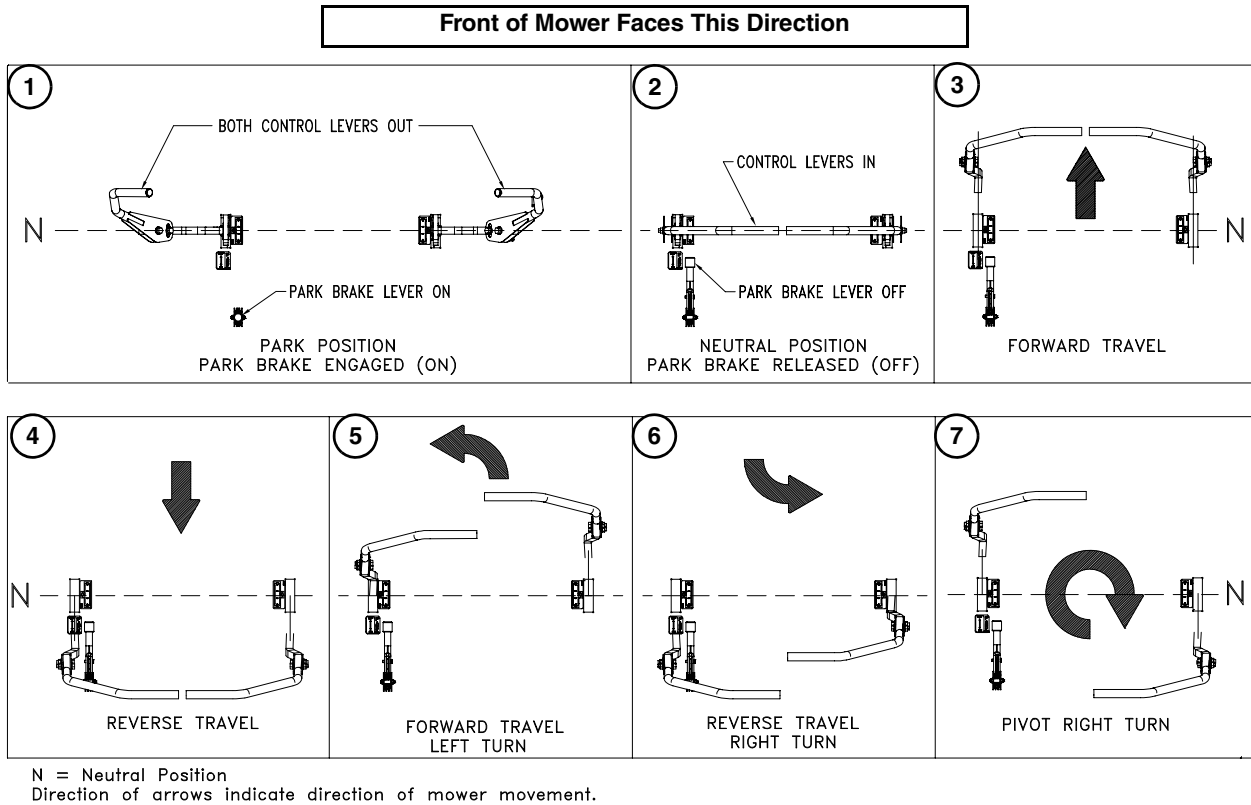

25880

Figure 2-9

### To Start and Increase Speed

Refer to Figure 2-9 on page 20:

After starting the engine, release park brake, and engage control levers by moving handles fully **(IN)**. This makes the levers ready for steering while traveling. Moving control levers an equal distance away from neutral will increase travel speed.

- Start forward travel by gently pushing on the control levers. The further forward the control levers are pushed the faster the travel speed.
- Start backing up by gently pulling on the control levers. The further back the control levers are pulled the faster the travel speed.

### To Decrease Speed and Stop

Refer to Figure 2-9:

#### **WARNING**

*In the event of a system shutdown while mowing, move control levers to neutral, and spread them fully apart. Also, engage the park brake lever to aid in slowing and stopping the mower.*

- When moving forward, pull back gently on control levers to decrease speed until neutral is reached.
- When backing up, push forward gently on control levers to decrease speed until neutral is reached.
- Move control levers to neutral to stop. (Ref. Frame #2)
- Spread both control levers fully apart and engage park brake when stopped. (Ref. Frame #1)

### To Steer

Refer to Figure 2-9:

- To Steer Straight While Traveling Forward (Ref. Frame #3):  
Push control levers forward an equal distance.
- To Steer Straight While Backing Up (Ref. Frame #4):  
Pull control levers rearward an equal distance.
- To Turn Left While Traveling Forward (Ref. Frame #5):  
Move right control lever farther forward from neutral than the left control lever.
- To Turn Right While Traveling Forward:  
Move left control lever farther forward from neutral than the right control lever.
- To Turn Right While Backing Up (Ref. Frame #6):  
Move left control lever farther back from neutral than the right control lever.
- To Turn Left While Backing Up:  
Move right control lever farther back from neutral than left control lever.
- To Make A Pivot Turn (Ref. Frame #7):  
Move one control lever forward and the other control lever back of neutral, this will allow the drive wheels to counter-rotate.

Section 2: Operating Procedures

**Towing Using The Rear Hitch**

**! WARNING**

*Do not attach a trailer, implement, or other device to the mower hitch that will produce negative tongue weight. Negative tongue weight can result in loss of control and cause injury or death to the operator.*

**IMPORTANT:** Do not pull a trailer or implement exceeding gross weight of 300 pounds and 50 pounds tongue weight. Never pull an implement engaged in the ground. Exceeding pull limits can result in loss of control and damage the mower.

**IMPORTANT:** Do not make turns so sharp as to cause trailer or implement being towed to come in contact with the mower. Damage may result.

**Safe Operating Instructions**

The safe operation of any machinery is a big concern to all consumers. Your Zero Turn Mower is designed with many built-in safety features. However, no one should operate this mower before carefully reading this Operator's Manual and all instructions noted on the safety decals.

**! DANGER**

*Prior to operating the mower, the operator should be thoroughly familiar with proper use and operation of the machine, should read the manual completely and thoroughly, and should have attempted slow moving maneuvers to become familiar with the operation of the machine before attempting normal speed operation. An inexperienced operator should not mow on slopes or on uneven terrain.*

**! DANGER**

*Always use seat belt with the Roll Over Protection System (ROPS). The ROPS can offer protection to the operator in a rollover situation only if that person is contained within the ROPS perimeter. Not using the seat belt in a rollover situation can throw the operator from the mower causing serious injury or death.*

**! DANGER**

*Low structures can make contact with the ROPS and flip the mower over backwards. Fold ROPS down when driving under low structures such as tree limbs and doorways.*

**! DANGER**

*Never direct discharge of material from mower deck towards people, animals or buildings. Keep discharge chute in its lowest position and never remove discharge chute unless a complete grass collection system is in place. Projectiles can suddenly, without warning, discharge from under the mower deck causing serious injury or death.*

**! DANGER**

*Do not mow with people present in the mowing area. Projectiles can suddenly, without warning, discharge from under the mower deck causing serious injury or death.*

**! DANGER**

*Never place hands or feet under the deck or attempt to make any adjustments to the mower deck while the engine is running or when blades are engaged. Mower blades rotating at a high speed cannot be seen and are located very close to the deck housing. Fingers and toes can be cut off instantly.*

**! DANGER**

*All guards including floor pan and seat platform must be installed and in good condition at all times during operation.*

**! WARNING**

*Mower deck and floor pan can be slippery when wet. Always step on anti-slip pads when possible. Never hurry. Always make sure your footing and hand hold is secure when climbing onto the mower to be seated.*

**! WARNING**

*Do not carry riders on the mower or in a cart towed behind the mower. Carrying riders can result in serious injury and/or death to rider and operator.*

**! WARNING**

*The tailpipe and muffler are very hot and can ignite dry grasses, brush and other flammable materials. Always keep area around muffler and tailpipe clear of debris. Allow muffler and tail pipe to cool completely before removing any debris to prevent severe burns to the body. Make sure all debris around the muffler have been removed before parking mower inside a building or garage.*

**! WARNING**

*Be aware of and avoid overhead hazards such as guy wires, tree limbs and brush that have the potential of stopping the mower or hitting and/or poking one while riding the mower. Mark any potential hazards and be alert to their presence.*

**! WARNING**

*Do not operate mower with a fuel leak. Fuel leaks can lead to fires and explosions. Repair all fuel leaks before putting mower back into service.*

**! WARNING**

*Do not operate mower at night without proper lighting. Restricted vision due to low light can damaging the mower and can cause serious injury or death to the operator and others nearby.*

## Section 2: Operating Procedures

### WARNING

*Always wear hearing protection, safety glasses, clothing that does not hang loosely, and shoes or boots when operating this machine. All shirts should be buttoned up the front and tucked in the trousers, long sleeve shirts should be buttoned at the cuffs. Some conditions may warrant extra safety gear be worn such as dust masks for dust inhalation and safety helmets.*

### WARNING

*Never drive recklessly. Terrain condition can affect mower traction and operator control. Reduce speed if surface conditions are uneven, rough, wet, slick, or when traveling over loose soil, sand, gravel, or other unstable surfaces.*

*Avoid mowing on steep inclines and inclines leading to sharp drop-offs, retaining walls, rocks, water, roads, highways, and other hazardous situations.*

*Do not make sudden uncontrolled changes with control levers. Change speed and direction with steady controlled movements of control levers. Take care when driving around trees so as not to scrape them.*

### CAUTION

*Always check area to be mowed for rocks and other debris before mowing.*

- ▲ Be familiar with all functions of this mower.
- ▲ Always park on level ground with control levers fully apart in neutral, park brake set, engine shut off, and switch key removed before leaving mower unattended.
- ▲ Do not operate mower with damaged parts. Repair all damaged and defective parts before putting mower back in to service.
- ▲ Do not allow anyone to operate this mower who has not fully read and comprehended this manual and has not been properly trained in its safe operation.
- ▲ Do not allow anyone under 16 years of age to operate this mower.
- ▲ Do not operate mower while drinking or under the influence of alcohol or drugs.
- ▲ Use extreme caution when driving through dry grass, brush and other fire hazard materials. Never stop or park over combustible materials. Keep grass and brush from collecting on and around engine and muffler parts.
- ▲ Drive Zero Turn Mowers up and down slopes, not across slopes. Use a walk behind mower when mowing across slopes.
- ▲ Do not operate Zero Turn Mowers on slopes greater than 15 degrees. They are heavy and can crush a person if they rollover sideways or flip over backwards.
- ▲ Stay two or more mower widths away from drop-offs such as ditches and retaining walls. Use a walk behind mower or string trimmer close to drop-offs.
- ▲ Do not drive too close to water. The surface near water is often soft, wet and unstable. The grass can be wet and slippery. Use a walk behind mower or string trimmer when close to water.
- ▲ Thoroughly inspect area to be mowed for unforeseen hazards in the grass such as rocks and other debris. Mark potential hazards that cannot be removed and be alert to their presence.
- ▲ Always wear long pants, ear plugs, safety glasses and safety shoes for personal protection. Some conditions may warrant extra safety gear be worn such as dust masks and safety helmets.
- ▲ Keep hands, feet, long hair, clothing, and jewelry away from moving parts and obvious pinch points to avoid entanglement. Clothing should be snug-fitting, buttoned and tucked in the trousers.
- ▲ Use extreme caution when cresting hills or when visibility is limited. Proceed slowly until you are sure conditions immediately ahead are safe.
- ▲ Do not operate mower on streets, highways, public roads, or where it may be a hazard to faster moving traffic.
- ▲ Do not touch engine, engine exhaust pipe and/or muffler while they are hot.
- ▲ Battery fumes are explosive. A spark will ignite battery fumes. Wear a face shield when charging or jumping a battery. Follow all battery safety rules in this manual.
- ▲ Avoid battery acid spills. Do not get battery acid on eyes, face, or other body parts. Flush eyes and other body parts immediately with water for at least 15 minutes if battery acid has gotten on them.
- ▲ Do not tow mower with its wheels on the ground. Always tow mower loaded on a trailer. Make certain the mower is properly secured to the trailer and its park brake is locked.
- ▲ Do not push other equipment with front of mower.
- ▲ Do not smoke or use electrical devices including cell phones while refueling.
- ▲ When refueling use a UL listed container that has a screen or filter. Set container on the ground before fueling to eliminate static discharge. Do not use Methanol fuel.
- ▲ Always maintain proper tire inflation. See “**Tire Inflation Chart**” on page 61.
- ▲ Always disconnect negative battery terminal before making adjustments to the mower’s electrical system or welding on the mower.
- ▲ Support this mower securely before working beneath. Chock wheels to prevent mower from rolling.
- ▲ Always check wheel lug nut torque values two hours after initial operation and two hours after each tire repair and/or replacement. Routinely check lug nut torque valves every 50 hours of operation. See also “**Torque Requirements**” on page 36.



## Section 2: Operating Procedures

### Good Operating Practices

**Engage blades with engine running at medium speed.** Pull up on blade engagement switch to start blades. Once blades are fully engaged and turning, increase engine speed to maximum operating speed.

**NOTE:** Engaging blades under heavy load (i.e. tall grass) or at high engine RPM can cause premature belt wear and/or belt damage.

**Cut grass with blades operating at full speed.** Your Zero Turn Mower operates at peak mowing performance and gives the best cut when the throttle is set at full rpm. This gives maximum power to the drive wheels and cutting blades when needed. Use control levers to control ground speed rather than engine rpm.

**The mower's control levers are very responsive.** For smooth operation, move levers slowly, avoid sudden movement. Skill and ease of operation come with practice and experience. Inexperienced operators may have a tendency to over-steer and lose control. Slow-moving practice maneuvers are recommended to become familiar with these characteristics before attempting normal speed operation.

**Approach depressions & raised obstacles carefully.** Sharp depressions or raised obstacles (such as gutters or curbs) should not be directly approached at high speed in an attempt to jump them as the operator could be thrown from the mower. Approach at a slow speed and angle one drive wheel at the obstruction. Continue at an angle until both wheels clear the obstruction.

**Protect turf by keeping both drive wheels rolling when making turns.** When turning on soft wet turf, keep both drive wheels rolling either forward or backward. Pivoting on a stopped drive wheel can damage the turf.

**Select a mowing pattern that discharges cut grass away from uncut grass.** Use a pattern utilizing left turns because cut grass is discharged to the right. Avoid discharging cut grass onto uncut areas as grass is then mowed twice. Mowing twice puts an unnecessary load on the mower and reduces mowing efficiency.

**Keep blades sharp.** Many problems with incorrect cutting patterns are due to dull blades or blades which have been sharpened incorrectly. Information on sharpening blades is listed in this manual's maintenance section. In addition, most communities have individuals or companies which specialize in sharpening mower blades. Blade sharpness should be checked daily.

### General Operating Information

After thoroughly familiarizing yourself with the Operator's Manual and completing the Operator's Checklist, you are almost ready to begin mowing.

Approach mower from the front and spread steering levers fully apart. Stand just to the outside rear of the left front anti-scalp wheel and with your right hand grab the left side steering lever for support. Taking care not to slip on the mower deck, step up onto the operator's platform

and comfortably seat yourself. The park brake lever just to your left and adjacent to the operator's seat should be fully raised and in the (ON) position. With both steering levers still wide apart, reach for the throttle and choke control on your right side. Position throttle control at half throttle and pull the choke to the "up/on" position. Insert your ignition key and rotate the ignition key clockwise until you hear the engine begin to start. Release the ignition key and push the choke to "down/off" position. Allow the engine to warm up momentarily. If your mower has just been running and the engine is already warm, using the choke is probably not necessary.

With the engine at half throttle, release the parking brake by pushing the lever forward and down all the way. Then reach forward and bring both steering levers equally together in the neutral position just in front of you. It's now time to test your steering skills. Gently push both steering levers equally forward. The farther forward you push the levers the faster you will go. Pull back equally and you will slow down coming to a stop when you reach the neutral position. Now slowly pull the levers back toward your body past neutral position. The mower will reverse direction and increase in speed as you pull further back. If you push one lever forward and pull one lever back the mower will do a zero turn in the direction of the steering lever closest to your body. Now take a few moments in a safe open area to practice maneuvering and steering your mower with the engine still at half throttle. Gradually increase your throttle speed until you feel totally confident of your mower steering and handling ability around obstacles and in tight areas.

It's now time to cut the grass. Hopefully, you have already removed any obstacles from the lawn that you do not want run over. With your mower at half throttle, place your right foot on the deck lift pedal and release and lower the deck to your preset cutting height. With your right hand, pull up on the cutting blade engagement knob and increase the engine speed to full throttle. You may now begin mowing. When you are done mowing or just want to take a break, make sure you do all of the following.

- Park on level ground if possible, throttle engine back, disengage cutting blades. place steering levers in wide-open neutral position, engage park brake, turn engine off, and remove switch key.
- Step carefully off the left side of the floor pan.
- You may want to chock wheels as an added measure of safety, if and when you must park on an incline.

In the unlikely event that you lose electrical power and the Zero Turn Mower shuts completely down, you will lose hydrostatic steering capability. Should the engine fail for any reason and you need to push or pull the unit a short distance for loading or servicing, make sure you open bypass valves on the transaxles.

The Land Pride Zero Turn Mowers are designed to deliver professional cutting quality, while delivering high productivity and sustained comfort over extended periods of operation. With just a little bit of practice you should become very good at operating your mower.

## Section 3: Adjustments

### WARNING

Unless specifically required, **Do Not** have engine running when servicing or making adjustments to the mower. Place both control levers in the park position and remove ignition switch key. Read and observe all “**Safety Warnings**” and “**Important Notes**” in this manual.

Repairs or maintenance requiring engine power should be performed by trained personnel only. To prevent carbon monoxide poisoning, be sure proper ventilation is available when engine must be operated in an enclosed area.

Your Zero Turn Mower was adjusted before it left the factory and checked for proper operation during pre-delivery set-up. However, break-in wear and continued use can cause some adjustments to change.

- Be alert for unusual noises while operating the mower. They could be signaling a problem.
- Visually inspect for abnormal wear or damage while servicing and making adjustments to the mower.

Proper servicing and adjustment is the key to the long life of any implement. With careful inspection and routine maintenance, you can avoid costly downtime and repair.

### WARNING

Keep your mower clean. Remove heavy trash and clippings from mower. Keep all moving parts, hydraulic system, engine cooling system, and exhaust system clean of trash and clippings. Accumulation of trash and/or clippings can cause fires, hydraulic overheating and excessive belt wear.

Clear away heavy build-up of grease, oil, and dirt. Especially clean in the areas around oil openings, fuel openings, and air inlets. Minute dust particles are abrasive to close-tolerance engine and hydraulic components.

Some repairs require the assistance of a trained service mechanic and should not be attempted by unskilled personnel. Consult your Land Pride service center when assistance is needed.

## Torque Requirements

Refer to “**Torque Values Chart**” on page 60 to determine correct torque values when tightening hardware. See “**Additional Torque Values**” at bottom of chart for exceptions to standard torque values.

## Tire Pressure

Before considering any adjustment, check air pressure in the tires. Unequal tire pressure will cause mower to drift to one side and cut grass at unequal heights. Refer to “**Tire Inflation Chart**” on page 61.

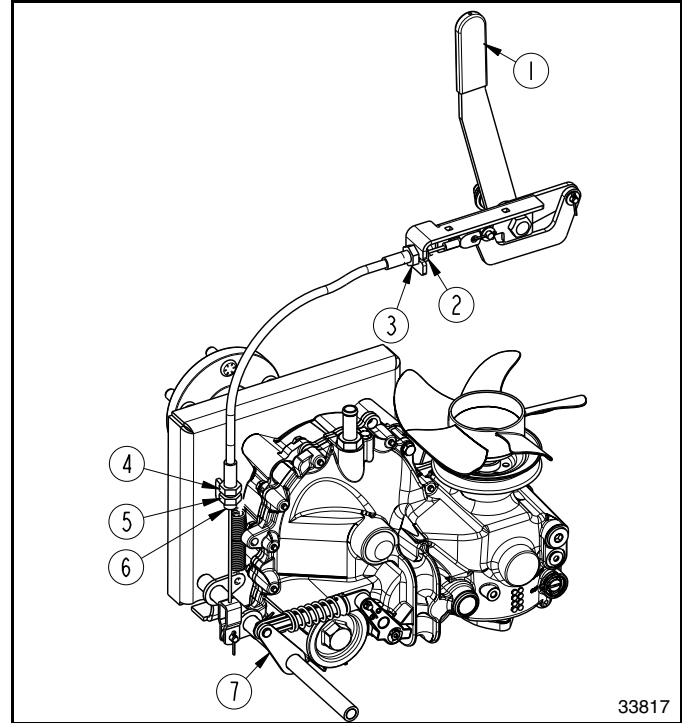

**Park Brake Adjustment**  
Figure 3-1

## Park Brake Adjustment

Over time, the park brake cable can stretch changing the effectiveness of the park brakes. Adjust park brakes if they do not hold on an incline or if the park brake lever applies too easy or too hard.

**Refer to Figure 3-1:**

1. Measure distance from nut (#5) to end of threaded mount (#6). If distance is about 1/8", skip to step 3. Continue with step 2 if distance is greater than 1/8".
2. Back nut (#5) away from engine platform until about 1/8" from end of threaded mount (#6).
3. Tighten jam nut (#4) against engine support plate and loosen nut (#2) 5 or 6 turns.
4. Skip to step 5 if brake lever (#1) applies too hard. Continue with step 4a below if park brake(s) do not hold on an incline or if brake lever applies too easy.
  - a. Tighten nut (#3) one-half turn at a time until applied brake lever pressure (#1) is satisfactory and then tighten nut (#2) against lever housing.
  - b. **Ensure cable adjustment allows linkage (#7) to return fully to disengaged position.** Not doing so may cause premature wear and unnecessary heat in the transaxle.
  - c. Recheck brake lever to make certain park brakes will hold mower on an incline. If necessary, repeat step 4 until park brakes will hold on an incline.

## Section 3: Adjustments

5. If brake lever (#1) applies too hard, continue with step 5a below:
  - a. Loosen nut (#3) one-half turn at a time until applied brake lever pressure (#1) is satisfactory and then tighten nut (#2) against lever housing.
  - b. **Ensure cable adjustment allows linkage (#7) to return fully to disengaged position.** Not doing so may cause premature wear and unnecessary heat in the transaxle.
  - c. Recheck brake lever to make certain park brakes will hold mower on an incline. If necessary, repeat step 4 until brakes will hold on an incline.

### Seat Reach Adjustment

Refer to Figure 3-2 & Figure 3-3:

The seat should be adjusted forward or rearward to a comfortable position to operate the deck lift pedal.

1. With operator sitting in the seat, place his or her right foot on the deck lift pedal.
2. Press down on the pedal as if to change the cutting height to determine if the seat is too close to the pedal, too far away, or at the correct distance.
3. If seat is at the correct distance, skip to “**Deck Lift Pedal Adjustment**” below.
4. If seat needs adjusting, pull spring loaded seat latch (#1) to the left and move seat forward or rearward to a comfortable setting.
5. Release spring loaded seat latch and recheck your reach from seat to deck lift pedal for comfortably.
6. If you are still uncomfortable with your reach to the deck lift pedal, then adjust the deck lift pedal as instructed below.

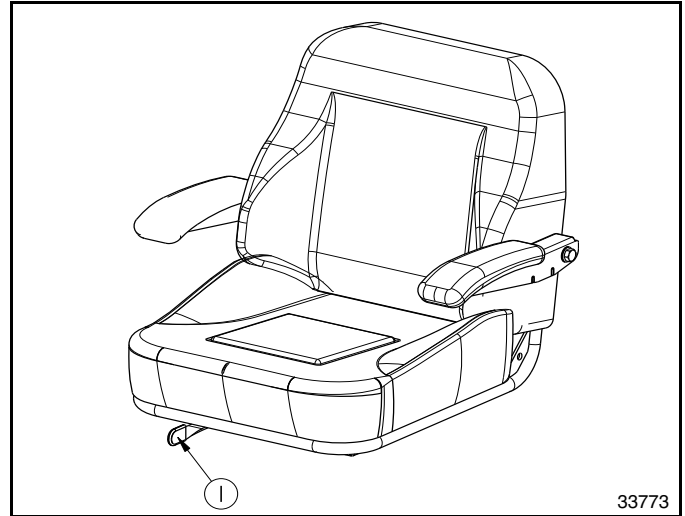

Deluxe Seat Reach Adjustment  
Figure 3-2

33773

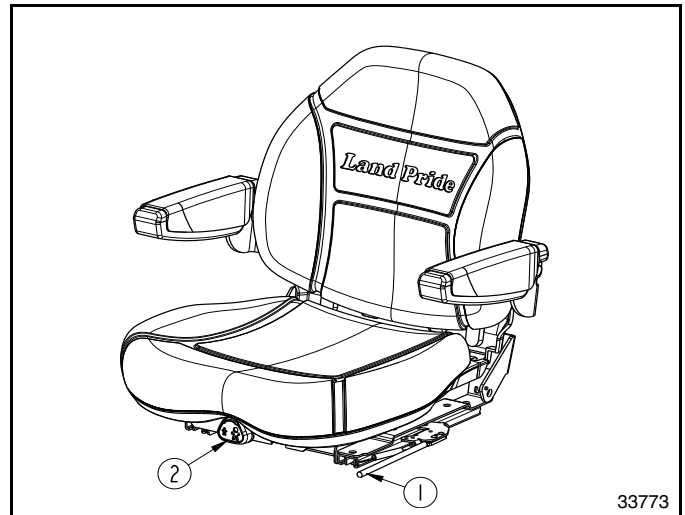

Suspension Seat Reach Adjustment  
Figure 3-3

33773

### Suspension Seat Weight Adjustment

Refer to Figure 3-3:

The Suspension Set can be adjusted to accommodate different weights to individualize the operator’s own comfort ride while mowing over uneven terrain.

1. Dial knob (#2) under the seat clockwise to accommodate more weight and counterclockwise to accommodate less weight.

### Additional Seat Suspension

Refer to Figure 3-4:

Additional seat suspension can be added under the seat pan by inserting 1 or 2 of the supplied bushings (#1) and springs (#2) into the existing springs (#3). Add additional bushing and springs as needed.

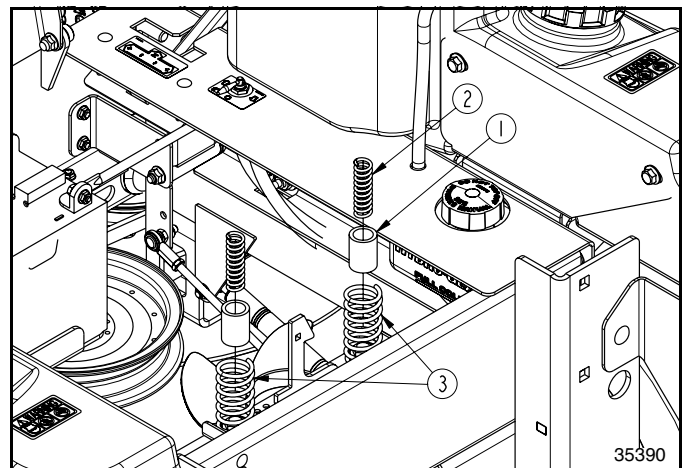

Stiff Seat Spring Kit  
Figure 3-4

35390

## Section 3: Adjustments

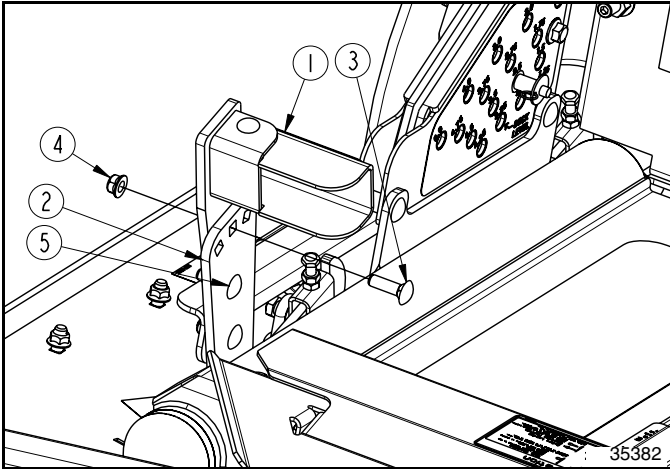

**Deck Lift Pedal Reach Adjustment**  
Figure 3-5

### Deck Lift Pedal Adjustment

Refer to Figure 3-5:

The deck lift pedal has three positions it can be adjusted to suit operator comfort.

1. Loosen carriage bolt (#5). Do not remove.
2. Unscrew hex flange nut (#4) and remove carriage bolt (#3) from lift arm (#2).
3. Rotate deck lift pedal to the preferred square hole and reinsert carriage bolt (#3). Secure carriage bolt with hex flange nut (#4).
4. Tighten 3/8"-16 x 1 1/4" GR5 carriage bolts (#3 & #5) to the correct torque.

### Steering Adjustments

The lower and upper steering levers may require readjusting to make operating the mower more comfortable.

#### Lower Control Lever

Refer to Figure 3-6:

The hydrostatic drive system is designed with spring return pump arms (#5) that will return the lower steering control levers (#2) to neutral when released from reverse position. If control levers do not return to neutral position when released from reverse position, adjust length of pump linkage rods (#1) as follows:

### WARNING

Make sure mower is turned (OFF) before making adjustments to pump linkage rods.

1. Push blade engagement switch to (OFF) and turn ignition switch (OFF).
2. Position control levers in neutral position as shown.

**NOTE:** Step 3 is not required but may be done if transaxle fan blades (#4) interfere with loosening jam nuts (#3).

3. If needed, remove fan mounting hardware and fan (#4) if jam nuts (#3) are not easily accessible.
4. Loosen jam nuts (#3) at both ends of linkage rod (#1) by 5 or more full turns (approximately 1/4"). One jam nut will be right-hand thread and the other will be left-hand thread.
5. Using the flat area (#1) on the linkage rod, rotate rod to lengthen or shorten it until lever arm (#2) aligns with neutral parking slot.
6. Tighten jam nuts (#3) at both ends to lock linkage rod in place.
7. Repeat steps 3 thru 6 for the other side.
8. If transaxle fans were removed, reinstall them and tighten their hardware to the correct torque.
9. Start mower engine and test control lever alignment by moving levers forward and backward before returning them to neutral position. The pump linkage rods (#1) are properly adjusted if the lower control levers (#2) are aligned with neutral parking slots in the mower housing when released.

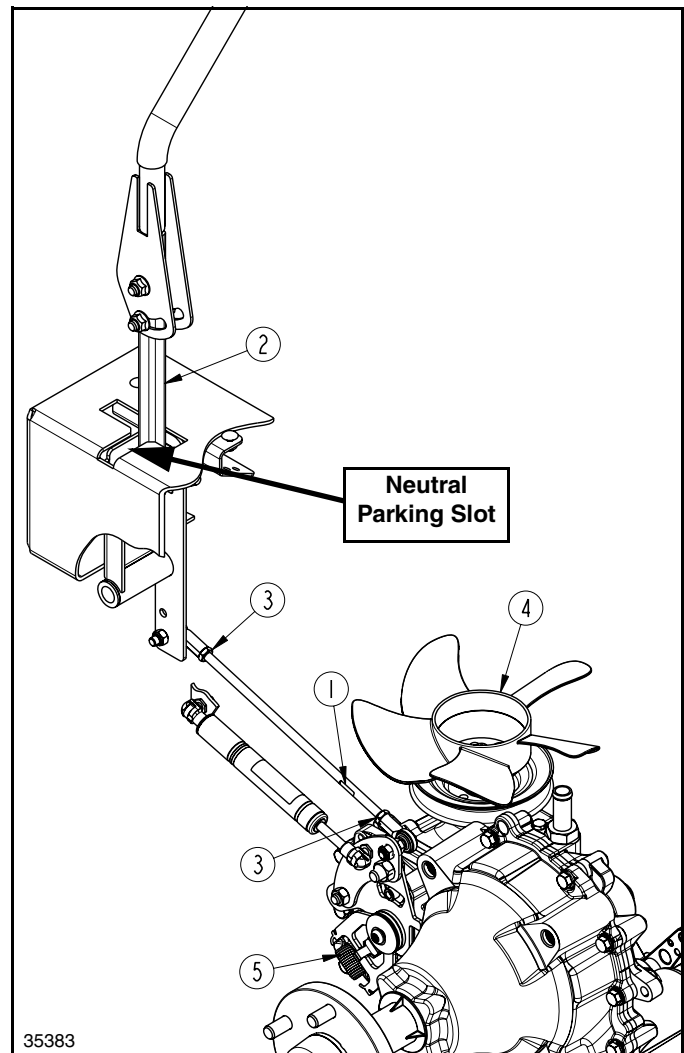

**Steering Control Linkage**  
Figure 3-6

Section 3: Adjustments

Upper Control Lever

**IMPORTANT:** Make sure lower control levers have been adjusted before adjusting upper control levers. See page 26 for lower control lever adjustments.

The upper control levers may be adjusted while in neutral position for height, reach, and forward travel to fit the operator's steering comfort zone.

Height Adjustment

Refer to Figure 3-7:

1. Adjust upper control levers (#2) vertically by removing bolts (#3), and hex flange locknuts (#4) that attach upper levers to the lower steering arms (#1).
2. Reposition upper control levers in holes A, B & C to a height that fits the operator's personal preference.
3. Reassemble bolts and hex flange locknuts in the same order they were removed without tightening them.

Reach Adjustment

Refer to Figure 3-7:

The upper control levers (#2) can be adjusted forward or rearward to make steering more comfortable.

**NOTE:** Adjust seat reach to operate the deck pedal comfortably before making "Reach Adjustment" to the upper control levers. See "Seat Reach Adjustment" on page 25 for instructions.

1. Loosen hex flange locknuts (#4) and pivot upper control levers (#2) forward or rearward to fit operator's personal reach preference.
2. Verify that the control levers align with each other when in neutral and tighten hex flange locknuts (#4) to the correct torque.

Forward Travel Adjustment

Refer to Figure 3-7:

"Reach Adjustment" instructions adjust upper control levers to be equally aligned while in neutral. However, with this adjustment, the mower may want to steer slightly to the right or left when pushing the levers equally forward.

Make the following adjustments if you prefer to have upper control levers equally aligned while in forward travel position instead of neutral position:

1. While driving forward, make necessary steering correction required to make the unit go straight and take careful notice of how the upper control levers are positioned. (The distance one lever is ahead of the other to make the mower travel straight.)
2. Stop mower on a level surface, place control levers in neutral, set park brake (ON), shut power off and remove switch key.

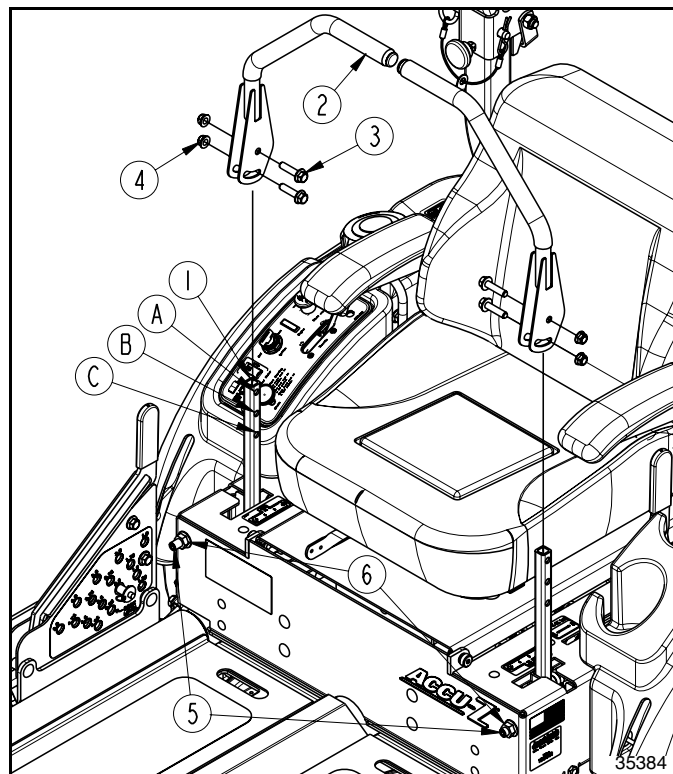

Control Lever Adjustment  
Figure 3-7

3. You can either adjust the trailing lever forward by the distance it was trailing or adjust the leading lever rearward by the distance it was leading.
  - a. Loosen hex flange locknuts (#4) on the side to be adjusted.
  - b. Reposition the lever forward or rearward by the distance it was trailing or leading.
  - c. Retighten hex flange locknuts (#4) to the correct torque.

**Example:**

If the right control lever is one inch ahead of the left control lever, stop unit and either adjust the right upper control lever rearward one inch or adjust the left upper control lever forward one inch.

Adjust Stops to Drive Straight at Full Speed

Refer to Figure 3-7:

The levers can be adjusted so that when both levers are all the way forward, the unit will travel in a straight line.

1. Loosen hex flange nut (#6) on the side to be adjusted.
2. Adjust set screw (#5) in or out by the distance leading or lagging.
3. Retighten hex flange nut (#6).

**NOTE:** This adjustment can also be used to regulate maximum forward speed.

## Section 3: Adjustments

### Belt Tensioning

There are two drive belts on the ZT3 mower. The ground drive belt is the upper belt that powers the rear wheels (see Figure 3-8). The deck drive belt is the lower belt and powers the deck blades (see Figure 3-10).

**IMPORTANT:** Do not over tension drive belts to compensate for a badly worn belt or pulley.

An over tensioned belt can cause the belt and drive components to break prematurely resulting in a safety hazard to the operator and bystanders.

An under tensioned belt can cause the belt to slip and become damaged.

### Ground Drive Belt Tensioning

Refer to Figure 3-8:

The ground drive belt (#5) remains in constant tension by means of a spring tensioned idler (#1). If belt slips under normal operating load conditions, retention spring (#4) by tightening eyebolt (#2). Replace belt when it becomes excessively worn or damaged. Instructions for replacing the ground drive belt are provided on page 39.

1. Check length of ground drive extension spring (#4) to verify if belt tension is correct. Installed spring length should be 7" +/- 1/8" (See Figure 3-9).
2. Adjust belt tension as follows:
  - a. Loosen hex whiz nut (#3A).
  - b. Tighten or loosen whiz nut (#3B) until spring length is 7" as shown in Figure 3-9.
  - c. When adjustment is complete, hold hex whiz nut (#3B) still while tightening hex whiz nut (#3A).

### Deck Drive Belt Tensioning

Refer to Figure 3-10:

The deck belt (#6) remains in constant tension by means of the spring tensioned idler (#5). If belt slips under normal operating load conditions, re-tension spring (#4) by tightening up eyebolt (#2). Replace deck belt when it becomes excessively worn or damaged. Instructions for replacing the deck drive belt are provided on page 38.

Vary spring length by adjusting length of eyebolt (#2). Additional adjustments to the spring length can be made by changing which hole in arm (#1) the spring is attached. Recommended holes for new belts are hole "A" for 60" decks and hole "B" for 72" decks.

1. With deck cutting height set at 3", check length of extension spring (#4) to verify belt tension. Installed spring length should be 7" +/- 1/8" (See Figure 3-9).
2. Adjust belt tension as follows:
  - a. Loosen hex whiz nut (#3A).
  - b. Tighten or loosen whiz nut (#3B) until spring length is 7" as shown in Figure 3-9.
  - c. When adjustment is complete, hold hex whiz nut (#3B) still while tightening hex whiz nut (#3A).

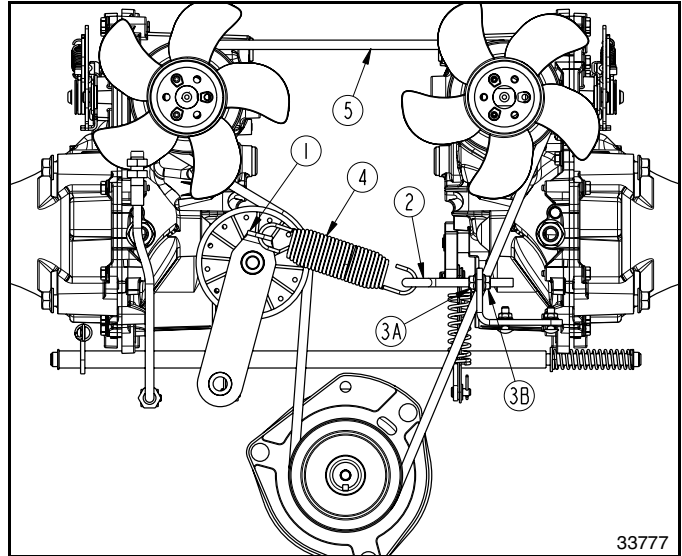

Ground Drive Belt Adjustment  
Figure 3-8

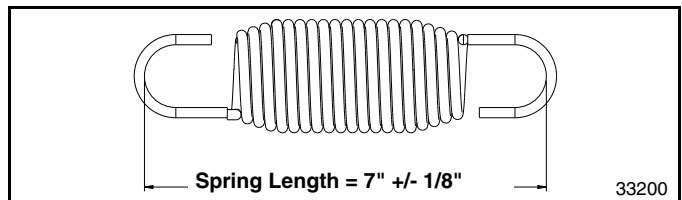

Take-up Spring Length  
Figure 3-9

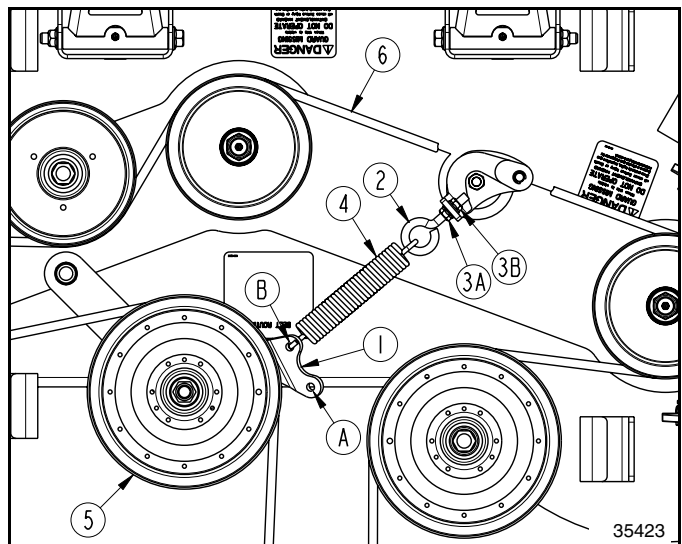

Deck Drive Belt Adjustment  
Figure 3-10

### Deck Leveling



### WARNING

Make sure blade engagement switch is (OFF), switch key is (OFF) and removed from ignition switch, control levers are (OUT), and park brake is (ON) before making adjustments.

## Section 3: Adjustments

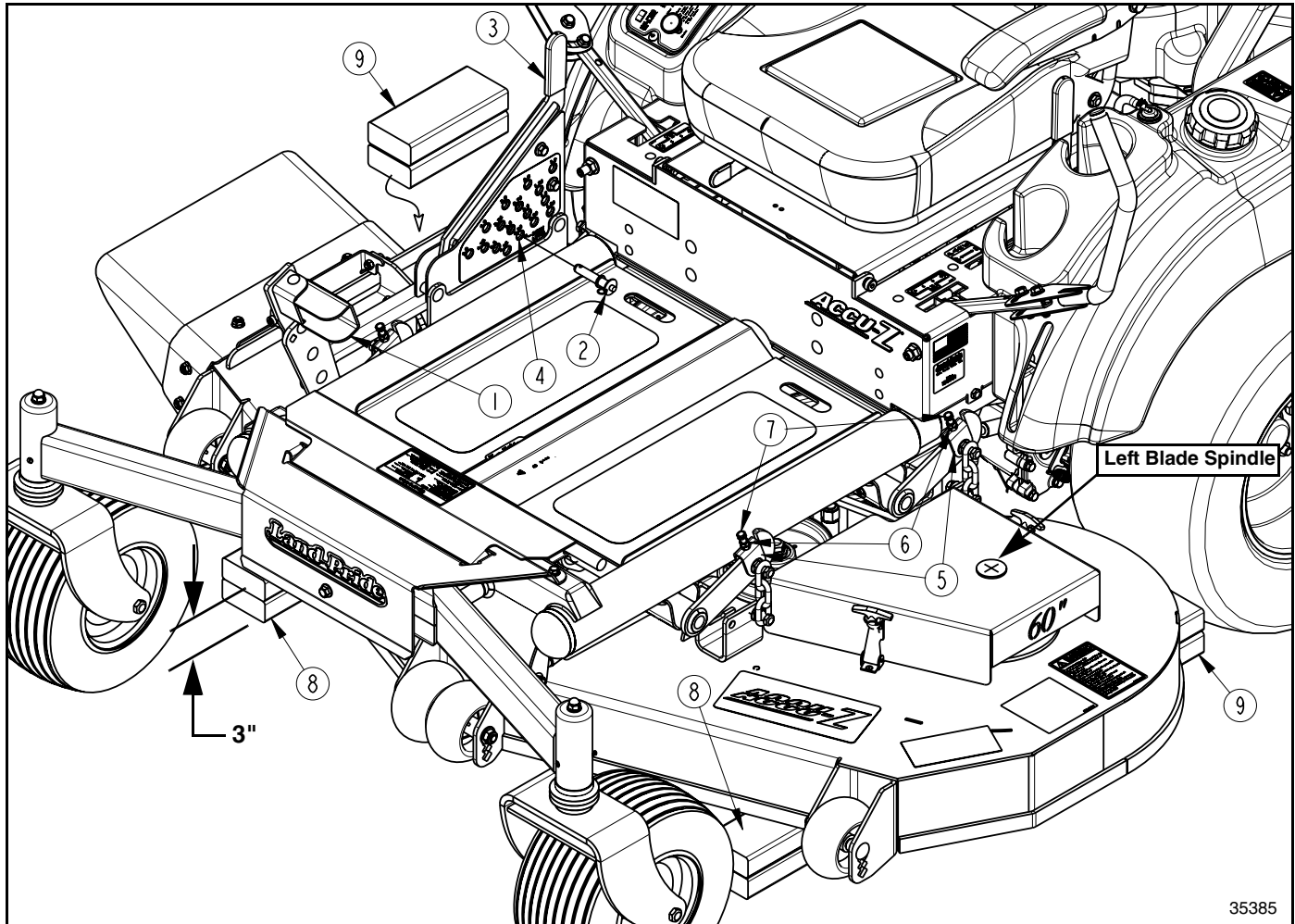

Deck Cutting Height &amp; Leveling (60" Deck Shown)

Figure 3-11

## Refer to Figure 3-11:

**IMPORTANT:** To remove & insert deck stop pin (#2), push center button on head of pin.

When level, the deck bottom edges should be 3" above ground level with deck stop pin (#2) inserted in **Deck Level / 3.25"** hole (#4). If needed, readjust deck height:

1. Check tire pressures to make certain they are properly inflated. See **"Tire Inflation Chart"** on page 61 for correct air pressure.
2. Park unit on a flat, level surface.
3. With your right foot, push deck lift pedal (#1) forward until transport lock (#3) catches and holds deck up. Deck should stay up after releasing foot pressure.

**NOTE:** Two 2" x 4" x 5" or longer boards may be stacked to make one 3" high block.

4. Place two 3" high blocks (#8) under the deck's front edge in-line with the left and right blade spindles.
5. Place two 3" high blocks (#9) under the deck's back edge in-line with the left and right blade spindles.

6. Refer to **Figure 3-12** on page 30: Remove all tension on deck lift assist springs (#7) as follows.
  - a. Raise floor pan up. See **"Accessing Area Beneath Floor Pan"** on page 17.
  - b. Back jam nuts (#4) and adjusting nuts (#5) counterclockwise to the end of eyebolts (#3).
7. Refer to **Figure 3-11**: Loosen jamb nuts (#6) on both sides of mower (4-places).
8. Insert stop pin (#2) into **Deck Level / 3.25"** hole (#4).
9. With your right foot, push deck lift pedal (#1) forward, pull back on transport lock handle (#3), and slowly release deck lift pedal to gently lower deck until deck weight is resting against stop pin (#2).
10. Adjust bolts (#7) up or down (4-places) on both sides of mower until deck is resting on all four 3" high blocks (#8 & #9) and is resting fully against deck stop pin (#2) and adjusting yokes (#5) are tight with no slack in support chains below adjusting yokes.
11. Hold bolts (#7) from turning and tighten jamb nuts (#6) on both sides of the mower (4-places).
12. Readjust deck lift assist springs. Refer to **"Deck Lift Assist Springs"** on page 30 for detailed instructions.

Section 3: Adjustments

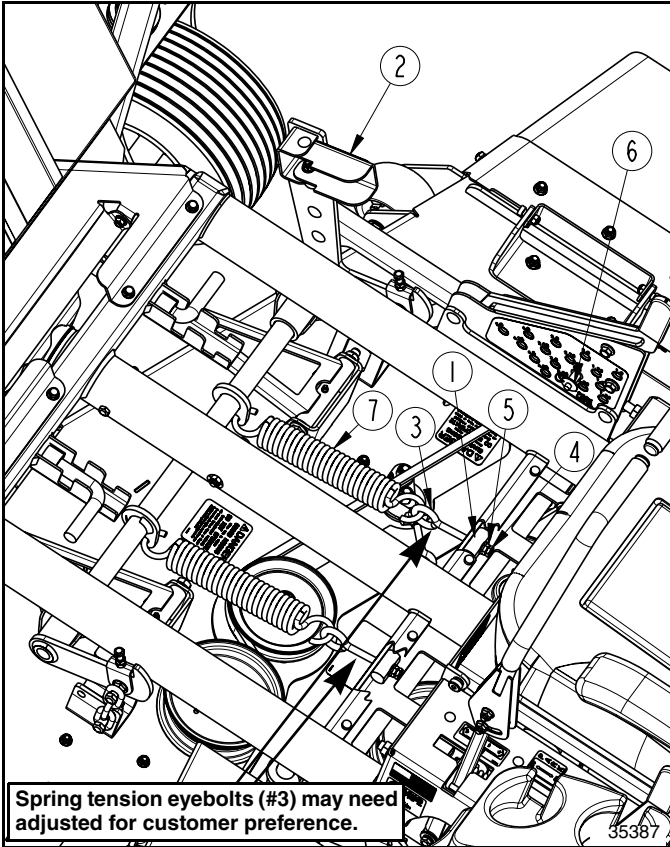

Deck Lift Assist Springs  
Figure 3-12

### Deck Lift Assist Springs

Refer to Figure 3-12:

There are two deck lift assist springs (#7). They are located under the floor pan and will require adjusting if deck weight bounces on and off of deck stop pin (#6) or if force to push deck lift pedal (#2) down is too great.

1. Lower deck to its lowest mowing position to ensure deck is still tight against stop pin (#6).
2. Rotate deck lift pedal (#2) out and raise floor pan up. See “**Accessing Area Beneath Floor Pan**” on page 17 for detailed instructions.
3. Back jam nuts (#4) away from adjusting nuts (#5).
  - Turn adjusting nuts (#5) clockwise an equal amount to increase spring tension and to make lifting the deck easier.
  - Turn adjusting nuts (#5) counterclockwise to decrease springs tension and to increase deck weight against stop pin (#6).
4. After adjusting nuts (#5) have been properly adjusted for both springs (#7), tighten jam nuts (#4) against adjusting nuts (#5).
5. Lower floor pan and rotate deck lift pedal (#2) back to operating position.

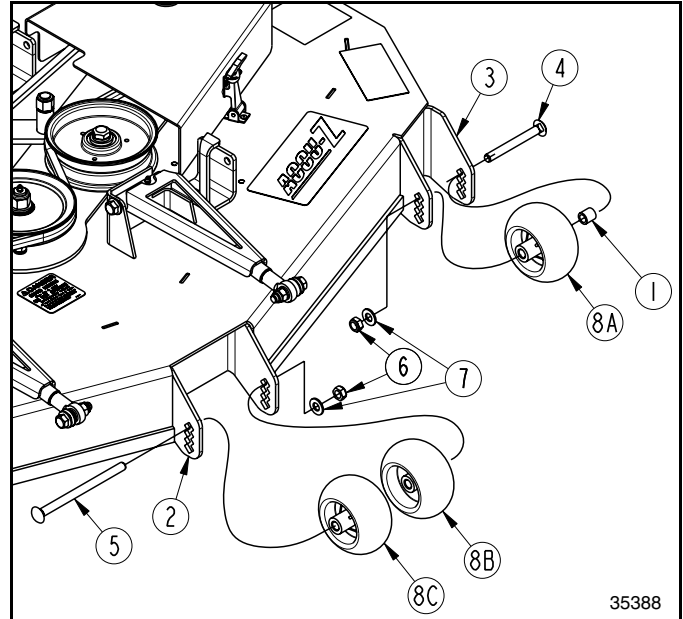

Anti-Scalp Roller Adjustment  
Figure 3-13

### Anti-Scalp Rollers

Refer to Figure 3-13:

The mower has four anti-scalping rollers. Their purpose is to minimize scalping of the ground when mowing on rough, uneven terrain. Their height should be adjusted after setting stop pin to the preferred cutting height.

**IMPORTANT:** The anti-scalp rollers will extend below deck bottom the distance shown below when mounted in the following holes:

- Top hole: rollers are even with deck bottom.
- 2nd hole: rollers are 1/2" below deck bottom.
- 3rd hole: rollers are 1" below deck bottom.
- 4th hole: rollers are 1 1/2" below deck bottom.
- Bottom hole: rollers are 2" below deck bottom.

For protection of deck and blades, it is best if the anti-scalp rollers are mounted in the lowest holes possible without them touching the ground.

For example:

If deck cutting height is set 1 1/2" above ground, the rollers should be mounted in the 3rd hole down or 1" below the deck bottom.

1. Position mower and deck on a flat level surface.
2. Set deck to the preferred mowing height. (Refer to “**Cutting Height**” on page 18.)
3. At middle bracket (#2), remove 1/2" hex nylock jam nut (#6) and carriage bolt (#5).
4. Reposition both anti-scalp rollers (#8B & #8C) up or down in mounting bracket (#2) until rollers are in the lowest hole possible without rollers touching the ground. See “**Important**” note on this page.



## Section 3: Adjustments

5. Reattach anti-scalp rollers (#8B & #8C) to mounting bracket (#2), with carriage bolt (#5), flat washer (#7), and hex nylock nut (#6). Tighten nylock nut to the correct torque.
6. At the left-hand anti-scalp roller (#8A), remove nylock jam nut (#6) and carriage bolt (#4).
7. Reposition anti-scalp roller (#8A) and spacer (#1) up or down in mounting bracket (#3) until roller is in the lowest hole possible without touching the ground. See Important note on page 30.
8. Reattach anti-scalp roller (#8A) and spacer (#1) to left-hand mounting bracket (#3) with carriage bolt (#4), flat washer (#7), and hex nylock nut (#6). Tighten nylock nut to the correct torque.
9. Repeat steps 6 thru 8 for the right-hand anti-scalp roller.

### Front Axle Pivot

Refer to Figure 3-14:

The front center pivot axle can be locked to hold front wheels rigid or unlocked to allow front wheels to float with the ground contour.



#### DANGER

Make sure blade engagement switch is (OFF), switch key is (OFF) and removed, control levers are (OUT), and park brake is (ON) before lifting floor pan to make adjustments.



#### WARNING

Lock front axle before lifting mower front. Body extremities can easily become pinched while lifting mower front if axle is not locked.

### Lock Front Axle Pivot

Refer to Figure 3-14:

1. Park with all four wheels on a flat level surface.
2. Be sure to adhere to the **Danger** and **Warning** comments on this page before opening floor pan (#1).
3. Rotate deck lift pedal (#5) back as shown.
4. Rotate floor pan (#1) up to access pivot locking components beneath.
5. Rotate bent pins (#2) up out of locking notch (#4).
6. Push bent pins forward until pins can be rotated down into locking notch (#3).
7. Rotate bent pins (#2) fully down into locking notch (#3).
8. Rotate floor pan (#1) down until closed.
9. Return deck lift pedal (#5) to operating position.

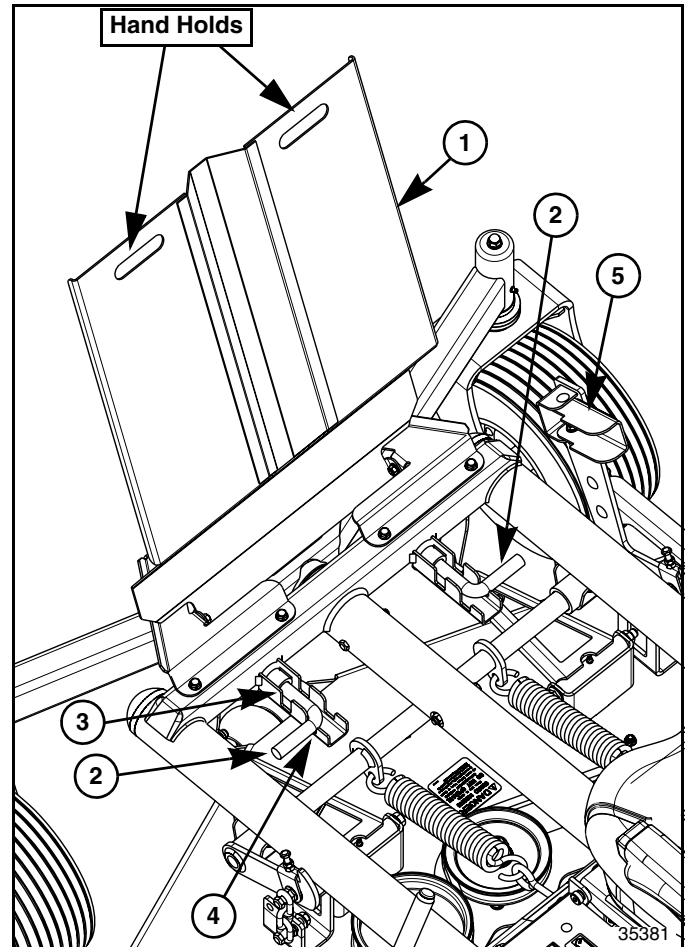

Pivot Locking Device (Floating Position Shown)

Figure 3-14

### Unlock Front Axle Pivot

Refer to Figure 3-14:

1. Park with all four wheels on a flat level surface.
2. Be sure to adhere to the **Danger** and **Warning** comments on this page before opening floor pan (#1).
3. Rotate deck lift pedal (#5) back as shown.
4. Rotate floor pan (#1) up to access pivot locking components beneath.
5. Rotate bent pins (#2) out of locking notch (#3).
6. Pull bent pins back until pins can be rotated down into locking notch (#4).
7. Rotate bent pins (#2) fully down into locking notch (#4).
8. Rotate floor pan (#1) down until closed.
9. Return deck lift pedal (#5) to operating position.

Section 4: Options & Accessories

### Folding Soft Top Canopy

Refer to Figure 4-1:

Keep the sun off with this easily assembled, ROPS attached canopy. Made with a lightweight aluminum frame and acrylic coated polyester, you'll be more comfortable during those sunny afternoons.

Soft Top Canopy .....357-194A



25686

Folding Soft Top Canopy  
Figure 4-1

### Head Light Kit

Refer to Figure 4-2:

Make seeing easier when completing a job after sundown and when parking your mower in a shed that is not well lit by attaching Land Pride's Light Kit.

Z Mower Light Kit .....357-160A

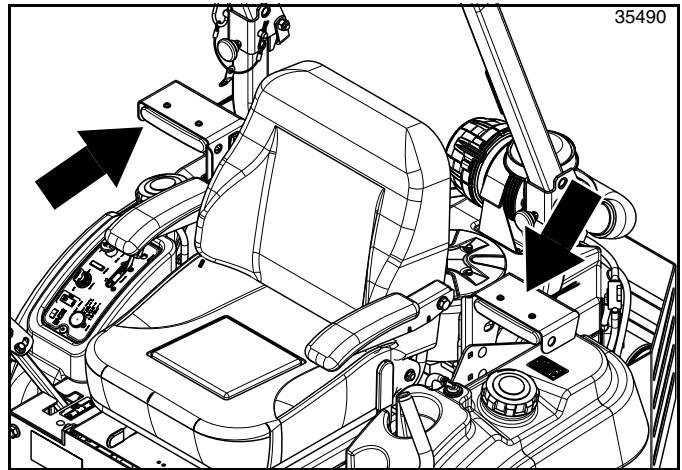

35490

Light Kit  
Figure 4-2

### Safety Flashing Light & SMV Sign Kit

Refer to Figure 4-3:

This slow moving vehicle sign and amber flashing light will allow commercial users to be noticed while working along busy road sides and while traveling, where permitted, on a road from one site to another site; such as from park to park and ball field to ball field.

ZT3 Safety Light & Sign Kit .....357-639A

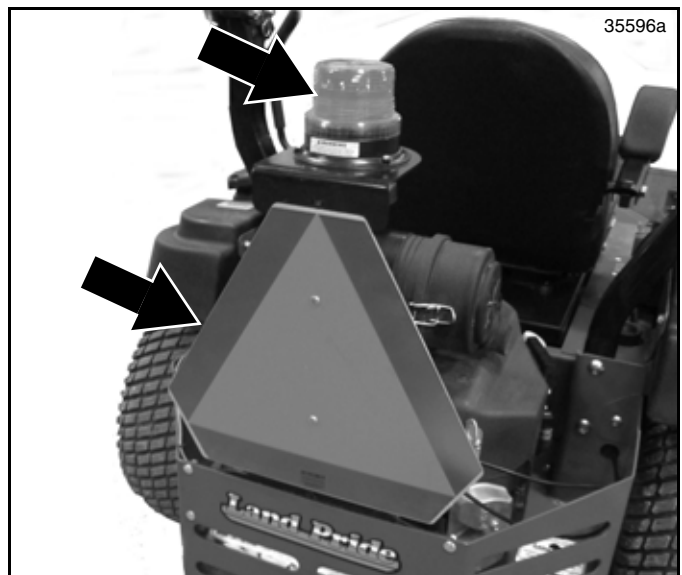

35596a

Safety Sign & Beacon Light Kit  
Figure 4-3

Section 4: Options & Accessories

**Lift Jack**

Refer to Figure 4-4:

Make accessing the underside of your deck easier with a front mount Lift Jack. It is especially useful for cleaning the deck underside, accessing the cutting blades and making front tire repairs.

Lift Jack . . . . . 357-209A

**Mulching Kit & Blades**

Refer to Figure 4-5:

Give your lawn that fresh cut grass look without those unsightly grass clippings showing by installing Mulching Blades (item #9) and Mulching Kit (Items #1 to #8) on your mower deck.

**NOTE:** Mulching Kit includes baffles and mounting hardware only. (Mulching Blades sold separately)

**For ZT360 mowers**

ZT360 Mulching Blades (Set of 3 blades) . . . 310-469A  
 ZT360 Mulching Kit (Baffles & Hardware) . . . 357-573A

**For ZT372 mowers**

ZT372 Mulching Blades (Set of 3 blades) . . . 310-473A  
 ZT372 Mulching Kit (Baffles & Hardware) . . . 357-577A

**Rear Wheels**

Refer to Figure 4-6:

The ZT360 Zero Turn Mower can be purchased with Standard rear wheels or optional offset rear wheels. Offset rear wheels give the mower a 4" wider rear wheel base. The ZT372 Models are furnished only with offset rear wheels. See Parts Manual for individual tire and rim Part Numbers.

**ZT360 mowers**

Standard Tire & Rim Assembly . . . . . 814-305C  
 Offset Tire & Rim Assembly . . . . . 814-484C

**ZT372 mowers**

Offset Tire & Rim Assembly . . . . . 814-484C

**Inductive Tachometer**

Attaches to the spark plug on single and twin cylinder engines for checking engine speed. Engines operating at optimal speed stay cooler and perform better.

Inductive Tachometer . . . . . 890-909C

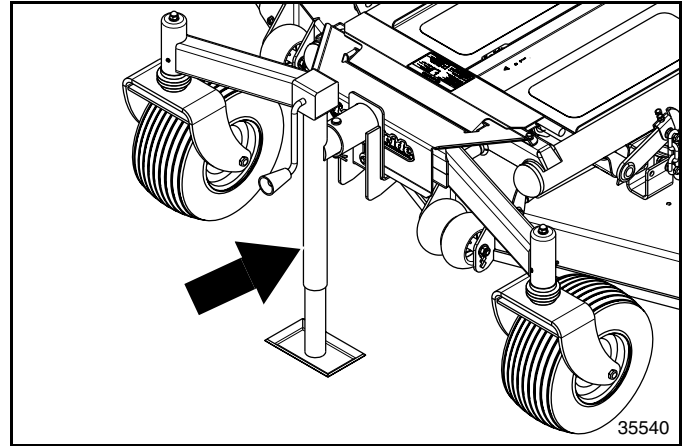

**Light Kit**  
**Figure 4-4**

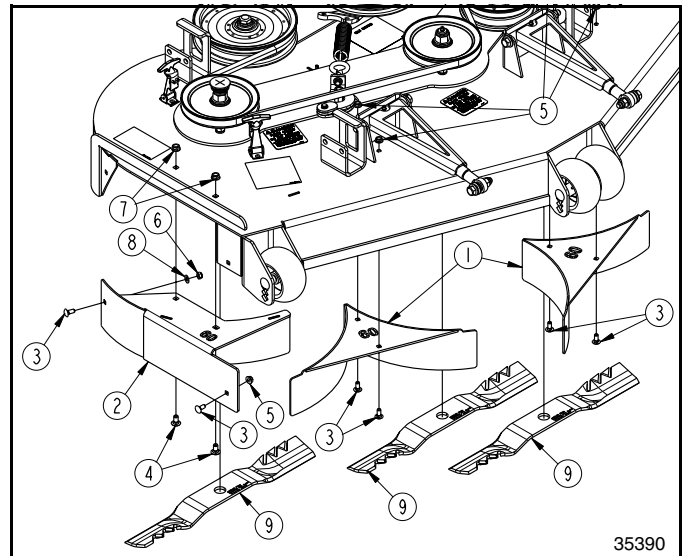

**Mulching Kit (Mulching Blades Shown)**  
**Figure 4-5**

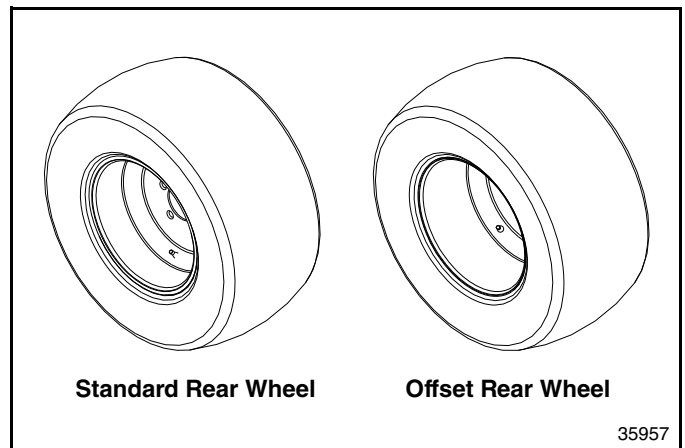

**Optional Rear Wheels**  
**Figure 4-6**

## Section 5: Maintenance & Lubrication

### Maintenance

Regular maintenance is the best prevention for costly downtime or expensive, premature repair. The following pages contain suggested maintenance information and schedules which the operator should follow on a routine basis.

Check initially and periodically for loose bolts and pins. Torque loose bolts per the “**Torque Values Chart**” on page 60. Remain alert for unusual noises, they could be signaling a problem. Visually inspect machine for any abnormal wear or damage. A good time to detect potential problems is while performing scheduled maintenance. Correcting problems as quickly as possible is the best insurance.

Clear away heavy build-up of grease, oil, and dirt, especially around the engine and under the seat platform. Minute dust particles are abrasive to close-tolerance engines and hydraulic assemblies.

Inspect mower daily for grass clippings, tangled wire and string. The underside of the mower deck will collect a build-up of grass clippings and dirt, especially when grass is wet or has high moisture content. This build-up will harden, restricting blade and air movement and will usually produce a poor quality of cutting. Therefore, debris should be routinely removed from under the deck. To do this, it will be necessary to raise and block the deck in the full-up position before scrapping build-up from underneath.

Some repairs require the assistance of a trained service mechanic and should not be attempted by unskilled personnel. Consult your Land Pride dealer when assistance is needed.

### Maintenance Safety

#### **DANGER**

*Repairs or maintenance specifically requiring engine power should be performed by trained personnel only. Control levers should be out. If control levers are to be operated, the tires should be properly supported off the floor. Enclosed areas should be properly ventilated to prevent carbon monoxide poisoning.*

#### **DANGER**

*Before working on or under the deck, make certain blade engagement switch has been shut off, deck has been properly blocked up, engine has been shut off, and ignition switch key has been removed for maximum safety.*

#### **DANGER**

*Exercise caution when working under the deck as the mower cutting blades are extremely sharp. Wearing gloves is advisable when working around or with cutting blades.*

#### **WARNING**

*Read and observe all safety warnings in this manual and in the engine service manual.*

#### **WARNING**

*Except when checking or changing components, always keep protective shields on for safety as well as for cleanliness.*

#### **WARNING**

*Keep your machine clean. Remove all deposits of trash and clippings. A dirty machine can cause engine fires and hydraulic overheating as well as excessive belt wear.*

#### **WARNING**

*DO NOT have engine running when servicing or making adjustments to the mower. Shut blade engagement switch off, move both control levers out, set park brake on, shut engine off and remove ignition switch key.*

#### **WARNING**

*Never run mower engine with seat pan raised. Hands and/or clothing can become entangled in the fan blades and drive belts causing serious injury or death.*

#### **WARNING**

*When possible, clean under the deck using a stick or similar instrument making sure that no part of the body, especially arms and hands are under the mower.*

#### **WARNING**

*Keep mower properly maintained. Do not make unauthorized modifications. An improperly maintained mower or one that has been improperly modified can be dangerous to operate.*

#### **WARNING**

*Do not operate mower with loose pins, bolts, and nuts. Loose hardware can result in a serious breakdown causing bodily injury or death.*

#### **CAUTION**

*Never modify engine RPM or any parts on the mower without authorization. Unauthorized modifications will void warranty to all parts directly and indirectly affected by the modification.*

#### **CAUTION**

*Do not alter Land Pride equipment or replace parts with other brands. Doing so can cause equipment to perform improperly and may lead to breakage that can cause bodily injury. Replace parts only with genuine Land Pride parts.*



### Maintenance Schedule

Service at Intervals Indicated	Every 25 Hrs	Every 50 Hrs	Every 100 Hrs	Every 200 Hrs	Every 500 Hrs	Refer to Page
Clean Mower, Deck & Engine Cooling System	Daily (After engine has cooled.)					
Verify Safety Start Interlock System	Daily (Before each use)					19
Inspect Unit For Loose Hardware & Damage	Daily (Before each use)					34
Visually Inspect Tires	Daily (Before each use)					61
Check Engine Oil Level	Daily (Before each use & every 4 hours thereafter)					44
Clean Engine Air Intake Screen	Daily (Before each use & every 4 hours thereafter)					44
Check Fuel Level	Daily (Before each use)					42
Inspect Fuel System For Leaks	Daily (Before each use)					42
Check Blades - Sharp & Securely Fastened	Daily (Before each use)					47 & 60
Check Discharge Chute - Make Sure It Is Properly Secured In Place	Daily (Before each use)					
Grease Blade Spindle Bearings	X					50
Change Engine Oil & Filter (1)		X				44
Clean Cylinder & Head Fins		X				
Check Battery Connections		X				12 & 36
Check Tire Pressure		X				61
Clean Engine Exterior (3)		X				
Check Transaxle Oil Level		X				40
Tighten Lug Nuts On Wheels (2)		X				60
Grease Front Axle Center Pivot	X					51
Grease Caster Wheel Bearings			X			52
Check Ground & Deck Belt Tension (4)			X			38
Check Transaxle For Oil Leaks (5)			X			42
Change Fuel Filter			X			43
Grease Deck Lift Points & Struts (8)			X/M			51
Replace Spark Plugs				X		53
Replace Air Cleaner Paper Element (6)				X		45
Grease Tele-Caster <sup>®</sup> Spindles (8)					X/A	52
Inspect Tethered Fuel Caps (8)					X/A	43
Change Transaxle Oil & Filter (7) (8)					X/A	41
Check & Adjust Parking Brakes (8)					X/A	24

**NOTES:**

- Initial engine oil and oil filter change is after the first 5 hours of operation. Thereafter, change engine oil and oil filter every 50 hours of operation. Change every 25 hours when operating the engine under dusty or dirty conditions, heavy load, high temperatures, and hot weather periods. Refer to Engine Owner's Manual.
- Torque lug nuts initially and after first 2 hours of operation.
- Remove cooling shrouds and clean cooling areas. Check oil cooler fins and clean as needed. Refer to Engine Owner's Manual.
- Inspect ground and deck belt tensions every 6 months or 100 hours and replace if worn or cracking is noticed. Otherwise, replace every 200 hours or 2 years whichever comes first.
- Inspect transaxles for oil leaks. Have your nearest Land Pride service center make repairs as needed.
- Replace air cleaner filter element if damaged, every 200 hours or every season (whichever comes first). Replace more frequently when used in dusty conditions.
- Initial Transaxle oil and filter change is between 25 and 50 hours of operation.
- X/M = Service per hours indicated in column or monthly (whichever comes first).  
X/A = Service per hours indicated in column or annually (whichever comes first).

### Tires

**IMPORTANT:** Use only tires recommended by Land Pride. Solid fill tires are not to be used on Zero Turn Mowers.

It is important for your safety and the safety of others that the tires have correct air pressure. Check air pressure in all four tires before each use. Visually inspect tires for loss of air throughout each day of operation. See “**Tire Inflation Chart**” on page 61 for correct tire pressure.

### Torque Requirements

Refer to “**Torque Values Chart**” on page 60 to determine correct torque values when tightening hardware. See “**Additional Torque Values**” at the bottom of the chart for exceptions to standard torque values.

### WARNING

Particular attention must be given to tightening the drive wheel lug nuts, blade spindle bolts, electric clutch bolt and transaxle mounting bolts and nuts. Not torquing these components correctly can result in the loss of a wheel, blade or burnt clutch. Any of the above situations can cause serious damage to the equipment and/or personal injury.

It is recommended that the following be checked after the first 2 hours of initial operation and after removal for repair or replacement. Thereafter, they should be checked every 50 hours of operation.

- Blade bolts (#2) in Figure 5-15 on page 47.
- Electric Clutch bolt (#17) in Figure 5-6 on page 38
- Wheel lug nuts (#6) Figure 5-7 on page 39.
- Transaxle mounting bolts (#3) in Figure 5-7 on pg. 39.

#### Refer to Figure 5-1:

- Retighten choke and/or throttle cable clamp screws to 35 in-lbs if they work loose or are loosened to make cable adjustments.
- See engine owner’s manual for all other engine torque values.

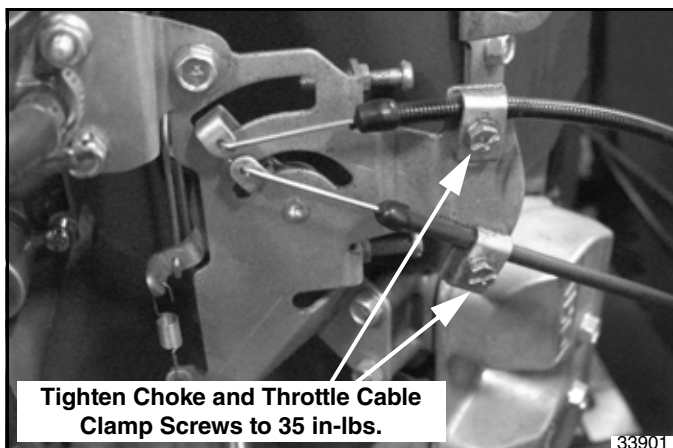

**Choke and Throttle Cable Clamp Screws**  
Figure 5-1

### Electrical System

#### Refer to Figure 5-2:

The mower is equipped with a 12 volt negative ground electrical system powered by a battery located under the seat. When worn out, replace battery with a maintenance-free garden mower 12 volt BCI group UL1HD with 245 cold cranking AMPs (CCA) or U1L-X with 300 CCA. Follow manufacturer’s maintenance, safety, storing, and charging specifications.

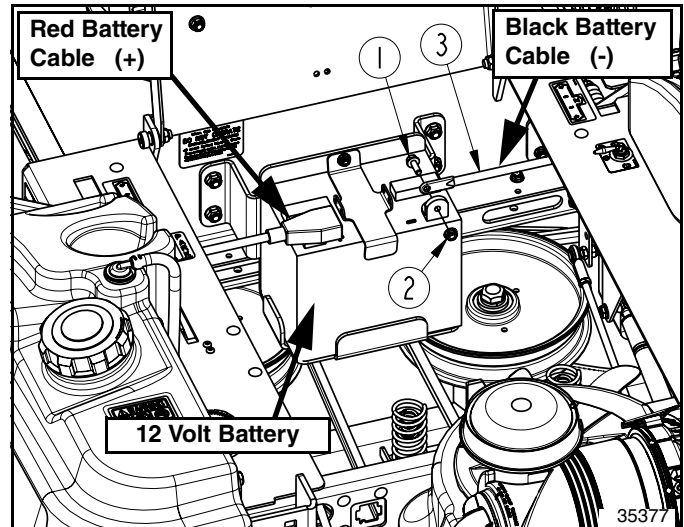

**Battery**  
Figure 5-2

### WARNING

Incorrect battery cable connections can damage the mower’s electrical system and cause battery cables to spark. Sparks around a battery can result in a battery gas explosion and personal injury.

- Always disconnect negative (black) cable from battery before disconnecting positive (red) cable.
- Always reconnect positive (red) cable to the battery’s positive (+) post before reconnecting negative (black) cable to the battery’s negative (-) post.

### WARNING

Keep battery terminals from touching any metal mower parts when removing or installing battery. Do not allow metal tools to short between battery terminals and metal mower parts. Shorts caused by battery terminals or metal tools touching metal mower components can cause sparks. Sparks can cause a battery gas explosion which can result in personal injury.

### WARNING

Acid can cause serious injury to skin and eyes. Avoid skin contact with battery acid and always wear eye protection when checking the battery. Flush area with clean water and call a physician immediately. Acid will also damage clothing.

## Section 5: Maintenance & Lubrication

### **WARNING**

Do not overfill battery. Electrolytes may overflow and damage paint, wiring and structure. Use soap and water when cleaning the battery. Be careful not to get soap and water into the battery. Use soda mixed in water to clean corrosion off the terminals.

### **WARNING**

Do not allow an open flame near the battery when charging. Hydrogen gas forms inside the battery. This gas is both toxic and flammable and may cause an explosion if exposed to a flame.

Common circuit problems are usually caused by electrical shorts, corroded or dirty terminals, loose connections, defective wire insulation, or broken wires. Switches, solenoids, and ignition components may also fail, causing a short or open circuit.

#### Refer to Figure 5-3:

The relay switch is for the starter circuit. The electrical system is protected by fuses located beneath the seat pan latch next to the relay switch. The fuses are:

- Clutch Engagement - 10 Amp, blade type
- Main Electrical System - 20 Amp, blade type

#### Refer to Figure 5-4:

To diagnose the electrical system, a general understanding of electrical servicing and use of basic test equipment is necessary for troubleshooting and making repairs. Major overhaul or repair of starter motor and charging system should be performed by trained technicians only. The following checks should be preformed if an electrical problem exist.

1. Remove fuse covers to access fuses. Visually inspect each fuse for a broken circuit. A test light can be used to check current across fuse terminals or remove the fuse in question and use an ohm meter to check for continuity across the terminals.
2. If fuses are good, use a voltmeter to check battery voltage. Recharge or replace battery if battery voltage is low.
3. If battery voltage is satisfactory, check cleanliness and tightness of terminals and ground connections.
4. If terminals and ground connections are clean and tight, visually inspect for defective wire insulation and broken wires. If necessary, use a test light to check for current to the component not operating.

#### Refer to Figure 5-5:

5. If the electrical problem is with the starter motor and steps 1 thru 4 above have been completed, then unplug the relay switch and replace it with a new relay switch.

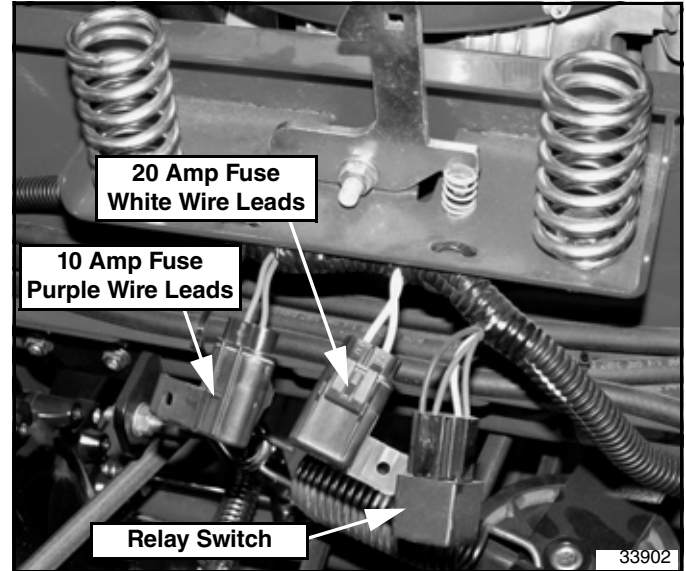

Wiring Harness Fuses  
Figure 5-3

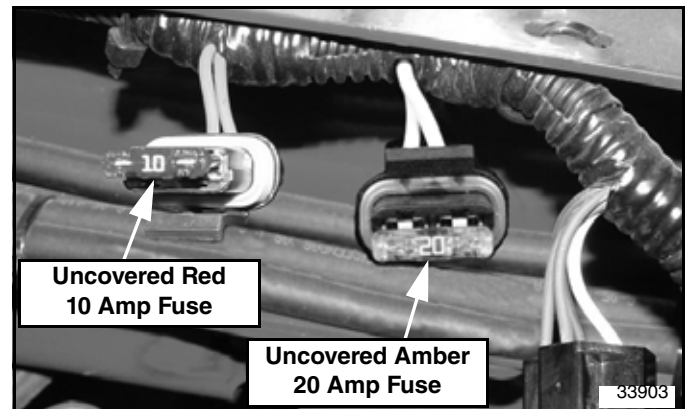

Fuses Shown With Cover Removed  
Figure 5-4

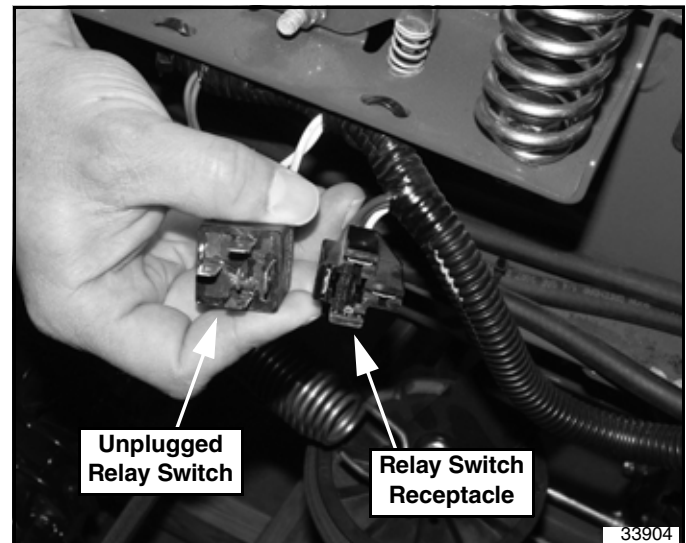

Relay Switch Shown Unplugged  
Figure 5-5

### Belt Maintenance



#### DANGER

Before raising floor pan or removing pulley guards, make certain blade engagement switch has been shut off, deck has been properly blocked up, engine has been shut off, and switch key has been removed for maximum safety. Replace all guards and floor pan before putting mower back into service. Repairs or maintenance requiring engine power should be performed by trained personnel only.

#### Refer to Figure 5-6:

Replace belts that show signs of severe cuts, tears, excessive weather checking, and cracking or burns caused by slipping. Slight raveling of belt covering does not indicate belt damage. Trim ravelings with a sharp knife.

Inspect pulley grooves and flanges for wear. A new belt or one in good condition, should never run against the bottom of the groove. Replace pulley when this is the case, otherwise belt will lose power and slip excessively.

Never pry belt onto a pulley as this will cut or damage fibers in the belt covering.

Do not bend belt into a tight radius as this can break belt cords and decrease belt life.

Keep oil and grease away from belts, and never use belt dressings. Any of these will destroy belt composition in a very short time.

### Deck Drive Belt Removal & Installation

#### Refer to Figure 5-6:

1. Park mower on a flat surface.
2. Make sure blade engagement switch is **(OFF)**, control levers are fully **(OUT)**, park brake is **(ON)** and engine switch key is **(OFF)** and removed.
3. Place deck height in the lowest position.
4. Remove deck belt covers and raise floor pan.
5. Release deck belt tension by placing a socket wrench with 11/16" socket on the over-center-release latch (#3) and turning counterclockwise. This will relieve tension on idler extension spring (#5).
6. Pull belt tension idler arm (#6) away from deck drive belt (#10) to provide maximum belt clearance and remove belt from spring tensioned idler (#9).
7. Remove existing belt (#10) from drive pulley (#12).
8. Remove existing belt (#10) from all remaining deck pulleys.
9. Install new belt (#10) in reverse order the belt was removed using belt routing shown in Figure 5-6.
10. Re-tension spring tensioned idler (#9) by turning the over-center-release latch (#3) clockwise until over-center-release locks in place. Check belt tension per **"Deck Drive Belt Tensioning"** on page 28.
11. Re-install deck belt covers and lower floor pan.

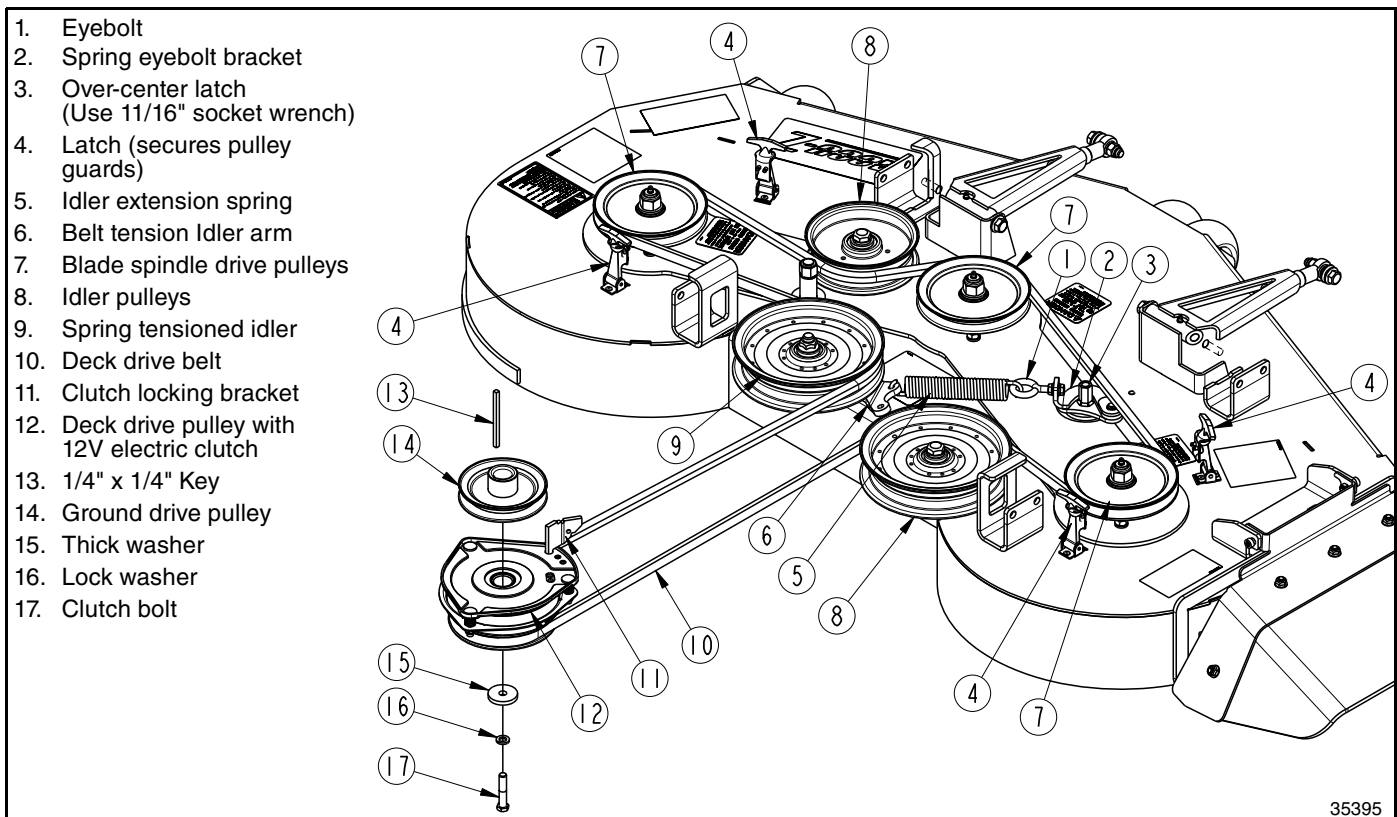

Deck Drive Belt Layout  
Figure 5-6



## Section 5: Maintenance & Lubrication

### Ground Drive Belt Removal & Installation

1. Park mower on a flat surface.
2. Make sure blade engagement switch is **(OFF)**, control levers are fully **(OUT)**, park brake is **(ON)** and engine switch key is **(OFF)** and removed.

#### **WARNING**

Make sure engine and engine muffler are completely cooled before working on and around the drive belt. Severe burns to the body could result if engine and muffler have not cooled.

3. Refer to **Figure 5-2 on page 36**: Disconnect black battery cable (-) (#3).
4. Place deck height in the lowest position. See **“Cutting Height”** on page 18 for detailed instructions.

#### Refer to **Figure 5-7**:

5. Remove deck drive belt (#11) from drive pulley (#14) as outlined in **“Deck Drive Belt Removal & Installation”** on page 38. This belt does not need to be removed from any of the other deck pulleys.

#### **CAUTION**

Use caution when releasing the spring-loaded pump idler arm as the take-up spring will snap the take-up pulley back if idler arm is released too soon and can cause an injury.

6. Release tension on ground drive belt (#10) by pulling on pump idler arm (#1) and carefully removing belt (#10) from take-up pulley (#8).
7. Slide belt (#10) off transaxle pump pulleys (#13), and ground drive pulley (#9).
8. Install new belt (#10) by sliding it onto ground drive pulley (#9) and over transaxle pump pulleys (#13).
9. Pull on pump idler arm (#1) and slide belt onto take-up pulley (#8).

#### **CAUTION**

Make certain to keep fingers from getting between belt and pulley when pulley is being released and belt tension is being re-established.

10. Slowly release spring loaded idler arm (#1) until belt is seated in the take-up pulley and belt tension is re-established.
11. Re-install deck drive belt (#11) to deck drive pulley (#14) per **“Deck Drive Belt Removal & Installation”** instructions on Page 38.
12. Make sure deck drive belt is routed properly on all of the deck pulleys and then re-tension deck belt idler per **“Deck Drive Belt Removal & Installation”** instructions on Page 38.

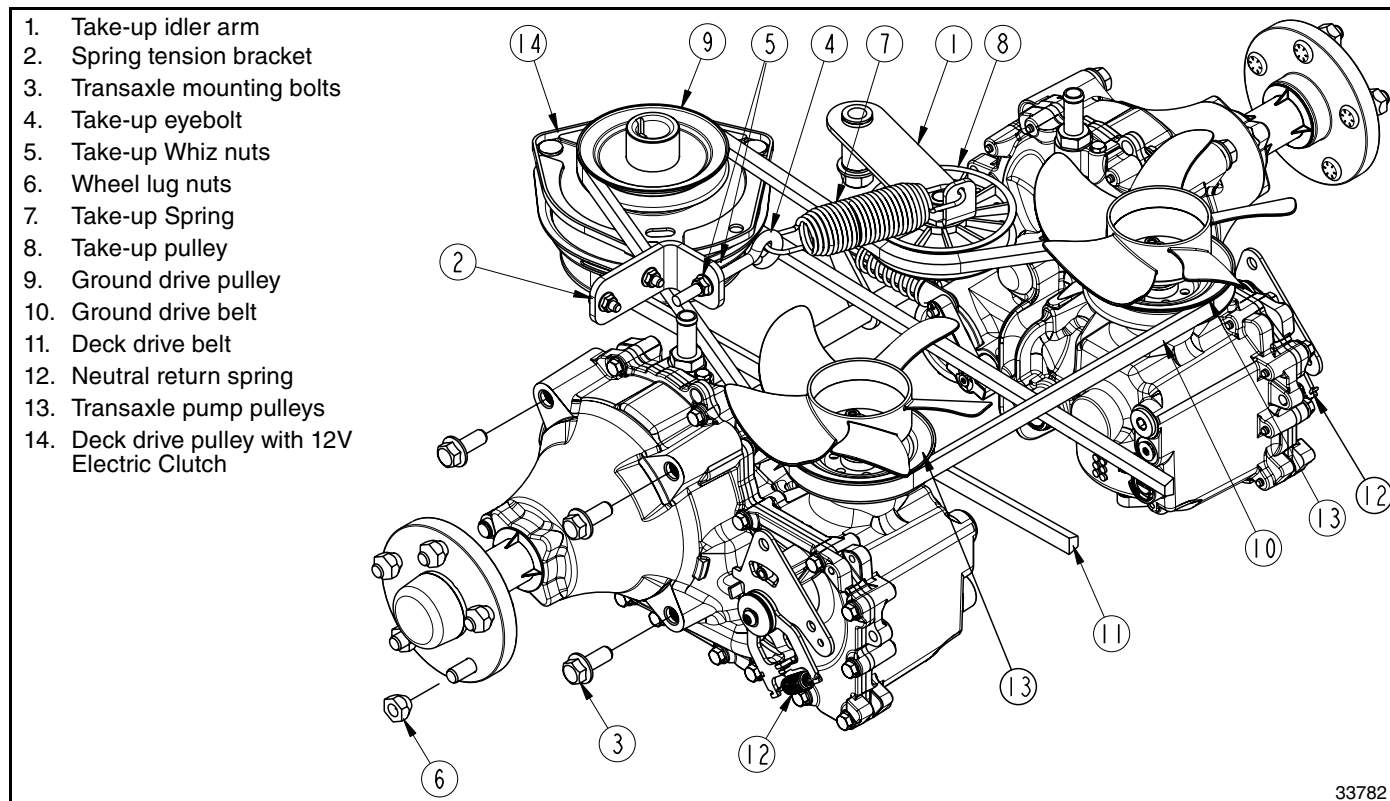

**Ground Drive Belt Layout**  
**Figure 5-7**

## Section 5: Maintenance & Lubrication

### Hydrostatic Drive System

#### **DANGER**

Hydraulic fluid under pressure can penetrate skin. Wear protective gloves and safety glasses or goggles when working with hydraulic systems. Use a piece of cardboard or wood rather than hands when searching for hydraulic leaks. If hydraulic fluid is injected into the skin or eyes, it must be treated by a doctor familiar with this type of injury within a few hours or gangrene may result. **DO NOT DELAY.**

#### **WARNING**

Always wear adequate eye protection when servicing the hydraulic system.

**IMPORTANT:** Do not use a high pressure washer on or around the hydraulic transaxles. Water intrusion will result and void the warranty.

**NOTE:** The transaxle units are equipped with bypass valves. For more information refer to **“Moving Mower with Stalled Engine”** on page 17.

The ZT360 & ZT372 mowers are equipped with two independent Hydro-Gear ZT5400™ Integrated Zero-Turn transaxle units. The units are located beneath the seat and require oil and filter changes on a regular basis. Check oil level in the expansion tanks daily. Stop operations immediately if transaxles are operating hot, noisy, or lacks power after operating for a short time. Wait for oil to properly cool and then check oil level in expansion tanks. If expansion tanks are properly filled with oil, have your nearest authorized Land Pride service department check the units and make necessary repairs before putting the mower back into service.

### Transaxle Oil Check & Filling

**Refer to Figure 5-8:**

The mower has two independent hydrostatic transaxles. Each transaxle will require separate oil checks. It is best to check oil when oil in the transaxle is between 50° and 100° F. See page 53 for oil specifications.

**IMPORTANT:** A transaxle must be purged anytime oil has been added to the unit or when unit has been opened to facilitate maintenance.

**IMPORTANT:** Clean debris from around fill cap before checking or adding oil to the unit.

**NOTE:** Be certain to place control arms in the outward position before rotating seat platform up.

1. Park mower on a flat level surface. Make sure blade engagement switch is **(OFF)**, control levers are fully **(OUT)**, park brake is **(ON)** and engine switch key is **(OFF)** and removed.
2. Clean transaxle exterior of any debris especially around the fill port cap. A degreaser may be needed.
3. Remove fill port cap (#8).
4. Oil level should be at the **“FULL COLD”** line (#6) or about 3/8" deep in the bottom of expansion tank with oil temperature between 50° and 100° F. If no oil is present in the expansion tank, add hydraulic oil until oil reaches the **“FULL COLD”** line. **Do not overfill.**
5. Install top port cap (#8) and hand tighten.
6. Recheck oil level once unit has been operating for approximately 1 minute.

**IMPORTANT:** The transaxles must be purged if no oil was present in the expansion tank prior to adding oil to remove any air that may have become trapped. See **“Transaxle Purging Procedures”** on page 41.

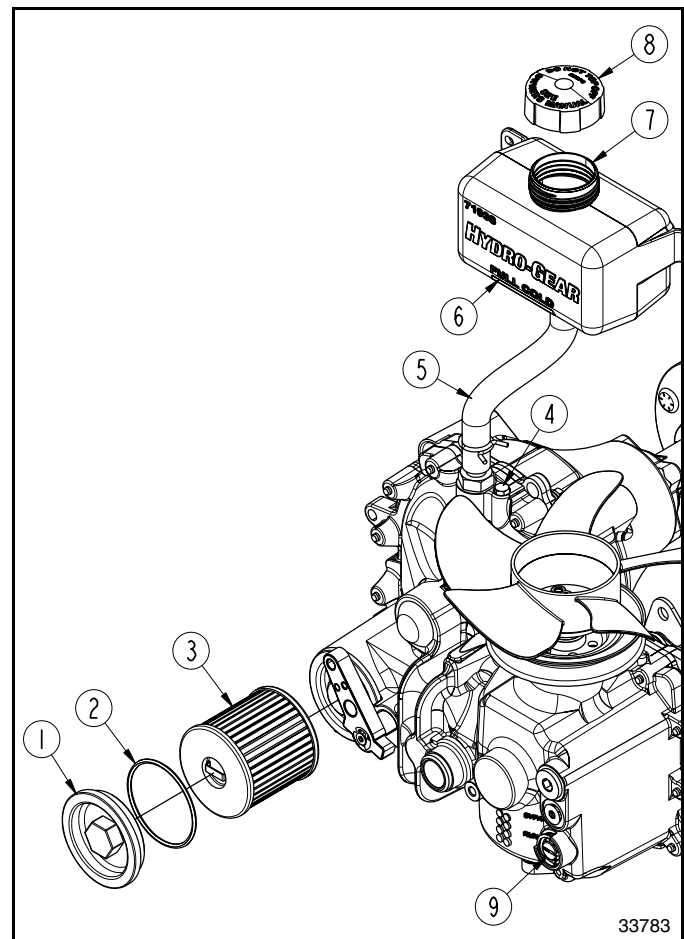

**Transaxle Oil Check & Filling (Left-hand Shown)  
Figure 5-8**

### Transaxle Oil & Filter Change

The mower has two independent hydrostatic transaxle systems. Each system will require separate oil and oil filter changes. It is best to change oil soon after using the mower while dirt particles are still suspended in the oil. See page 53 for transaxle oil specifications.

Initially, change oil and oil filters after the first 25 to 50 hours of operation. Thereafter, change oil and filters every 200 hours or every year whichever comes first. Two filters are required with each oil change. They may be purchased from your nearest Land Pride dealer. See page 53 for filter part numbers.

**IMPORTANT:** The transaxles must be purged after every oil change. See “**Transaxle Purging Procedures**” on this page.

**IMPORTANT:** Refer to Figure 5-8 on page 40. Clean debris from around oil filter cap (#1), oil fill vent port plug (#4), and expansion tank cap (#8) before removing any caps and draining hydraulic oil.

1. Park unit on a flat level surface. Stop engine and remove ignition key. Make sure blade engagement switch is **(OFF)**. Spread control levers fully apart.

**Refer to Figure 5-8 on page 40:**

2. Begin on the left side by placing an oil pan (12" or more in diameter with approximately 8 qt. or more capacity) beneath the transaxle oil filter cover (#1).
3. Clean transaxle exterior and expansion tank of any debris. A degreaser may be needed.

**NOTE:** Drain old oil filters of all free flowing oil prior to disposal. Place used oil and oil filter in appropriate containers and deliver to an approved collection facility.

4. Unscrew oil filter cover (#1) and allow oil to drain.
5. Remove oil ring (#2) from oil filter cover (#1). Dispose of oil ring properly.
6. Remove expansion tank cap (#8) to facilitate drainage.
7. Allow oil to drain until it has slowed to a slow drip. Be sure to properly dispose of the oil.
8. After oil has completely drained from transaxle housing, remove used oil filter (#3) from transaxle housing and dispose of properly.
9. Install new oil filter per instructions below:
  - a. Insert new oil filter into transaxle housing.
  - b. With a clean rag, clean the inside surface of the oil filter cover where the oil ring seats against it.
  - c. Apply a thin coat of oil on new rubber oil ring (#2) and install new oil ring onto filter cover (#1).
  - d. Screw oil filter cover on until it makes contact with the surface it seats against.

- e. Tighten oil filter cover to specified torque. See “**Additional Torque Values**” on page 60 for specified torque value.

**Refer to Figure 5-8:**

10. Remove top port vent plug (#4). This will allow the transaxles to vent air during oil fill.
11. Fill transaxle by adding specified oil to expansion tank (#7) until oil appears at the top port vent plug opening (#4). See “**Hydrostatic Transaxle Specifications & Capacities**” on page 53 for specified oil type and quantity.
12. Install top port vent plug (#4) and tighten.
13. Continue to add oil to the expansion tank until oil reaches the full cold line (approximately 3/8" up from the bottom of expansion tank).

**NOTE:** Fill tube (#5) should be hand squeezed several times to burp out air and to drain oil from the expansion tank into the tube. Be careful not to damage the tube while squeezing it. Use a protective cloth wrapped around the tube if using a tool to squeeze such as a pair of pliers.

14. Reinstall expansion tank cap (#8) by hand. Be careful to not overtighten.
15. Wipe off all excess oil. A degreaser may be needed to remove excess oil.
16. Repeat steps 1 thru 15 for the right side.

### Transaxle Purging Procedures

It is critical that air is purged from the hydrostatic drive system to keep it efficient. This is because compression and expansion rate of air is higher than that of oil.

This purge procedure should be implemented any time the hydrostatic system has been opened to facilitate maintenance or after oil has been changed.

Symptoms of a hydrostatic system that has not been purged may be:

1. Noisy operation.
2. Lack of power after short term operation.
3. High operation temperature and excessive expansion of oil.

**Refer to Figure 5-8 on page 40:**

Before purging system, make sure fill tubes (#5) are full of oil and expansion tanks (#7) are filled to the cold full line (#6). Squeeze all air from fill tubes and add oil if expansion tanks are low. See “**Hydrostatic Transaxle Specifications & Capacities**” on page 53 for oil specifications. The following procedures are best performed with mower drive wheels off the ground and then repeated under normal operating conditions. If this is not possible, the procedure should be performed in an open area free of any objects or bystanders.

1. Open both transaxle bypass valves (#9) by rotating valves vertical to “**BYPASS**”.

## Section 5: Maintenance & Lubrication

2. Start engine and place both control levers in neutral. Slowly move control levers completely forward and rearward 5 to 6 times.
3. Close both bypass valves by rotating them horizontally to “RUN”.
4. With engine running and control levers in neutral, slowly move levers forward and rearward 5 to 6 times.
5. Stop engine and check fill tubes (#5) and expansion tanks (#7). Squeeze all air from fill tubes and add oil to expansion tanks if they are low.

**IMPORTANT:** The transaxle is considered purged when transaxles are at the proper oil level, operate at normal noise levels, oil temperatures are not excessively high, and mower does not lack power.

6. It may be necessary to repeat steps 1 to 5 until all air is completely purged from the system, transaxle operates at normal noise levels, and travels at normal speeds.

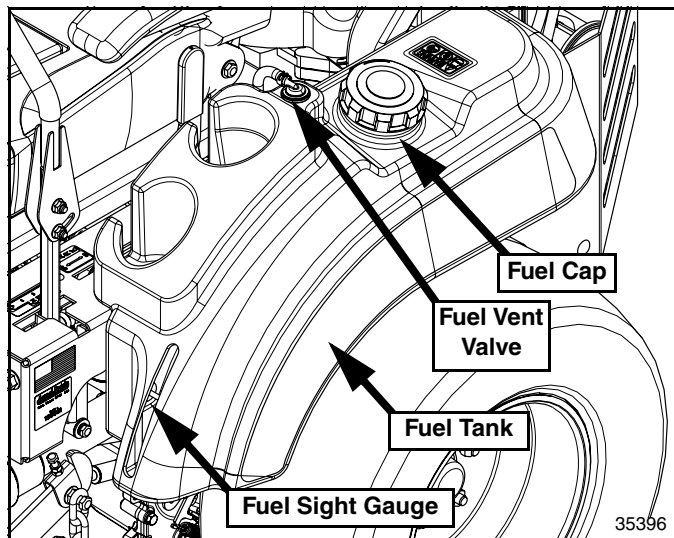

Fuel Tanks (Left Side Shown)  
Figure 5-9

### Fuel System

Refer to Figure 5-9:

The fuel tanks are located in the mower fenders. Total capacity of each fuel tank is 6 U.S. gallons. Fill tank when fuel shows low in the fuel sight gauge. Before filling, push blade engagement switch (**OFF**), move both control levers (**OUT**), set park brake (**ON**), and turn switch key (**OFF**). Allow engine to cool before filling tank.

Clean dirt from around fuel tank cap. Remove cap and begin filling. Do not fill fuel tank to the top. Fuel will expand in hot weather and seep out through the fuel tank vent system. When finished, screw cap back on until it makes a clicking noise and ratchet action that can be heard and felt when tight. Wipe up any spilled gasoline. Use regular unleaded gasoline with an (R+M)/2 octane rating of 87 or higher.

**IMPORTANT:** The fuel system can be damaged if the wrong fuel is used. Never use methanol, lead gasoline, or unleaded gasoline containing more than 10% ethanol. Do not mix oil with gasoline.

Land Pride recommends adding correct amounts of gas stabilizer/conditioner in the fuel. For best results, follow engine manufacturer's directions. Using a fuel stabilizer/conditioner in the fuel can provide benefits such as:

1. Keeps gasoline fresh during storage of 90 days or less. Drain fuel tank if storage is longer.
2. Cleans engine during operation.
3. Eliminates gum-like varnish build-up in the fuel system.

### DANGER

- Replacement of fuel system parts (i.e. gas caps, hoses, fuel tanks, fuel filters, etc.) must be the same as original parts. Fire and/or explosion can occur if not followed.
- Observe safe fuel handling precautions. Fuel is flammable and vapors are very explosive. An explosion or fire can burn, destroy and kill property, animals and people.
- Do not fill tank with engine running or while engine is hot. Allow engine to cool before filling. Fuel spilled over engine, muffler, or hot objects may result in a fire or explosion.
- Allow engine to cool before servicing the fuel system.
- Do not smoke while handling fuel or around the fuel tanks.
- Do not fill fuel tanks to the top. Fuel will expand in hot weather and seep out through the fuel tank vent system.
- Screw gas cap on immediately after filling a tank. Never operate mower without gas caps installed.
- Clean up any gasoline spills immediately.
- Keep fuel away from open flame or spark.
- Store mower away from open flame and sparks.
- Refuel outdoors preferably, or in well ventilated areas.
- Never attempt to start the engine when there is a strong odor of gasoline fumes present. Locate and correct cause.
- Do not operate mower with a fuel leak. Repair all fuel leaks before putting mower back into service.
- Never buy more than a 30 day supply of gasoline and store it in an approved container out of children's reach.
- Do not fill gasoline containers inside a vehicle, on a truck, or on a trailer. Interior carpets and plastic truck bed liners insulate the container and slow loss of static charge.
- When practical, remove equipment from the truck or trailer and refuel the equipment with its wheels on the ground. If this is not possible, then refuel the equipment on the truck or trailer using a portable container and not a gasoline dispenser nozzle. If a gasoline dispenser nozzle must be used, keep nozzle in contact with rim of fuel tank or container opening at all times until fueling is complete.
- Gasoline is a poison that is harmful or fatal if swallowed.
- Avoid prolonged breathing of vapors. Long-term exposure to vapors can cause serious injury and illness.
- Keep face away from nozzle and gas tank opening.
- Keep gas away from eyes and skin.

## Section 5: Maintenance & Lubrication

### Evaporative Emission Control System

All Land Pride Zero Turn Mowers are EPA compliant as of January 1, 2012 production date and include a decal located on right side of engine stating the following: "This Equipment meets U.S. EPA Evap. Standards:"

This Evaporative Emission Control System requires no regularly scheduled maintenance but should be inspected periodically, and thoroughly examined at least once a year at the beginning of the mowing season:

1. Inspect all fuel system components including tanks, vents, hoses, clamps, fuel filter, valves, and fittings for leaks, cracks, and loose connections. Make repairs as necessary.
2. The fuel tank is equipped with a tethered cap. Ensure tether is present and secured to the cap.
3. The fuel cap has been designed to provide audible and tactile feedback indicating that proper sealing has been achieved. Ensure that this function is present and that no fuel leaks from the filler neck during usage. If fuel leakage is ever noticed at this point, the fuel cap must be replaced immediately.

### Fuel Filter

Refer to Figure 5-12 on page 44:



#### DANGER

Empty fuel tank before replacing fuel filter to keep fuel from leaking out and creating a fire/explosion hazard.

The fuel filter is installed in the fuel line between the fuel tank and engine fuel pump. Location of fuel filter will vary depending on which engine your mower is equipped with. See engine owner's manuals for exact location of fuel filter and instructions on removal and installation.

Refer to Figure 5-10:

Replace fuel filter annually at the beginning of each mowing season or after every 100 hours of operation, whichever occurs first. (A plugged filter is considered a maintenance item.) This will keep the fuel filter from becoming plugged causing poor engine performance and unexpected downtime. Be sure to install filter with Flow Arrow pointing towards engine side of fuel line.

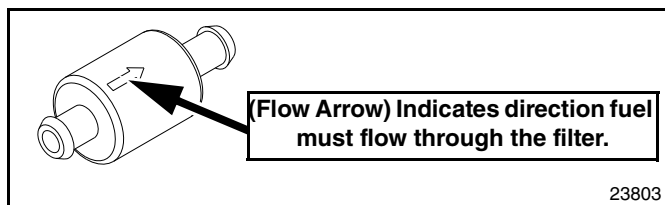

Fuel Filter  
Figure 5-10

23803

### Drain Fuel Tank

Refer to Figure 5-11:

1. Park unit on a flat surface. Make sure blade engagement switch is **(OFF)**, both control levers are **(OUT)** and park brake is **(ON)**. Stop engine and remove ignition key.
2. Disconnect negative battery cable from battery.
3. Trace fuel line from tank to be drained to the Left/Right Fuel Tank Valve located on right side of seat. Remove fuel line hose clamp at the Left/Right Fuel Tank Valve and remove fuel line.
4. Place end of fuel line into a gas can or a drain pan to drain fuel tank.
5. When fuel tank is drained, reattach fuel line to the left/right fuel tank valve with previously removed hose clamp.

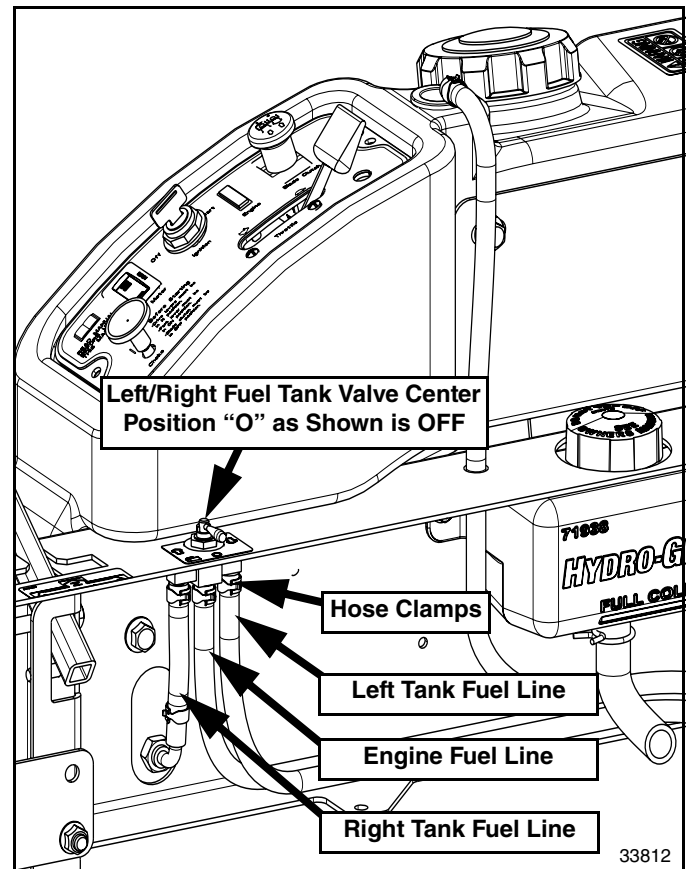

Fuel Lines (Raise Seat Platform to Access)

Figure 5-11

### General Engine Maintenance

Detailed instructions and recommendations for break-in and general maintenance are specified in the Engine Operator's Manual. Please refer to this manual for engine servicing, lubricating oil levels with capacity and viscosity recommendations, bolt torques, etc. **The engine warranty is backed by the engine manufacturer.** Special attention should be paid to applicable data which is not duplicated here.

## Section 5: Maintenance & Lubrication

### Engine Oil & Oil Filter

See “**Engine Specifications & Capacities**” on page 53 and “**Engine Operator’s Manual**” for oil type, capacity, and maintenance schedule. Check oil daily and after every 4 hours of operation. Mower must be sitting level when checking oil. Change engine oil and oil filter after the first 25 to 50 hours of operation and per engine manufacturer’s recommendations thereafter. Change oil more frequently if mower is operated in extremely dirty conditions.

**IMPORTANT:** Make certain engine is level and you are inserting the dipstick correctly when checking oil. Incorrect oil levels can cause engine problems.

### Check Engine Oil

**Refer to Figure 5-12:**

1. Park on a level surface, shut engine off and allow time for oil to cool and drain into the sump.
2. Clean area around oil fill cap/dipstick (#1) of dirt and debris before removing it. Unscrew oil fill cap and wipe dipstick clean.
3. Check oil level on dipstick by insert dipstick fully in **without screwing it in** and removing again to check oil level.
4. If oil level on the dipstick is near or below lower limit mark on dipstick, add recommended oil until it reaches the full mark. **Do not overfill.**
5. Reinstall oil filler cap/dipstick by screwing it in firmly.

### Change Engine Oil

**Refer to Figure 5-12:**

1. Park unit on a flat surface. Make sure blade engagement switch is **(OFF)**, both control levers are **(OUT)** and park brake is **(ON)**. Stop engine and remove ignition key.
2. Place a suitable container on the ground beneath oil drain valve (#3).
3. Unscrew oil drain valve (#3) until oil flows freely and valve head offers some resistance. Do not unscrew valve any farther.
4. Remove oil filter (#4) and let remaining oil drain out. Make certain the existing O-ring is not stuck to filter base (#2). Discard existing O-ring and filter in a manner that is compatible with the environment.
5. Clean engine oil filter base (#2). Coat new oil filter O-ring with clean engine oil and screw new oil filter (#4) onto engine oil filter base.
6. Hand tighten new oil filter until O-ring seats against oil filter base. Finish tightening by turning filter to the specifications provided in the Engine Operator’s Manual.
7. Retighten drain valve (#3).
8. Dispose of used motor oil in a manner that is compatible with the environment. Do not throw used oil in the trash, pour it on the ground, or down a drain.
9. Fill engine with the correct oil and quantity provided in the Engine Operator’s Manual and specifications on page 53 of this manual. Do not overfill with oil.
10. Replace oil fill cap/dipstick, start engine, and check oil filter for leaks.
11. Stop engine and check oil level. See “**Check Engine Oil**” on this page.

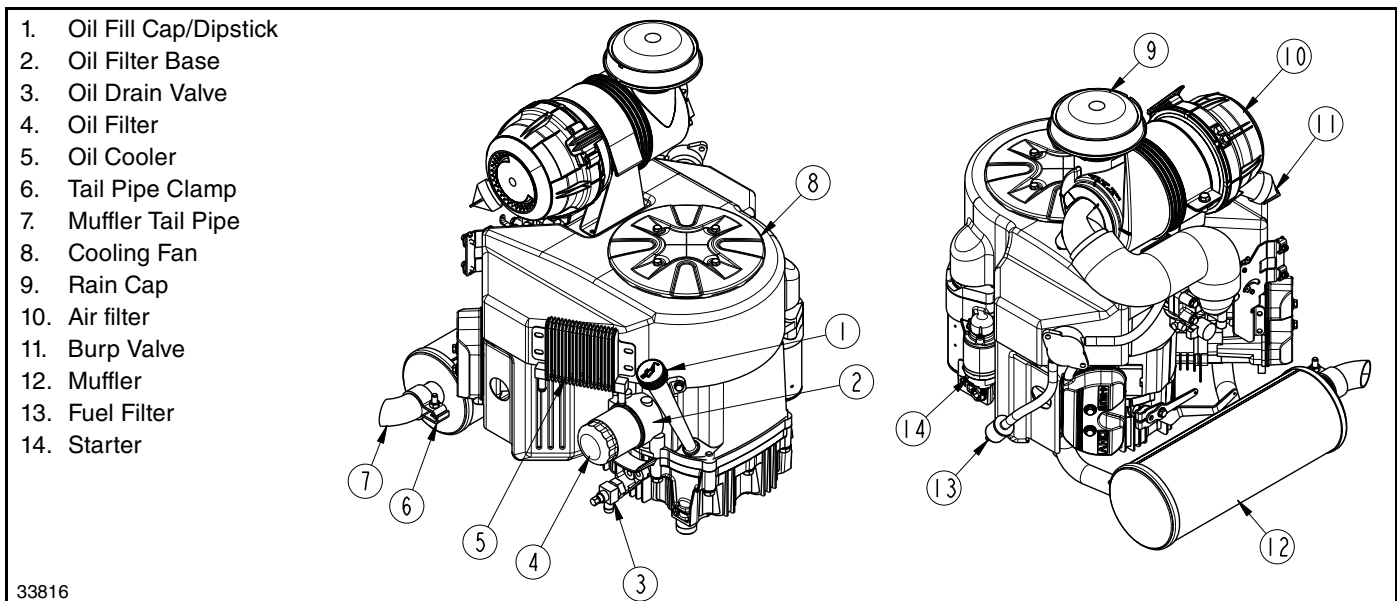

**Engine Components**  
**Figure 5-12**

Section 5: Maintenance & Lubrication

### Engine Air Filter

Refer to Figure 5-13:

A specially designed dry filter is standard equipment and supplies clean combustion air to the engine. Perform engine air filter maintenance per the Engine Operator's Manual and "Maintenance Schedule" on page 35.

**IMPORTANT:** Do not operate engine with a damaged air filter or without air filter elements. Dirt will enter engine causing dust induced engine damage.

**IMPORTANT:** Do not block air intake to canister such as placing an object in front of the air intake opening.

1. Replace filter element every 200 hours or every year, (whichever comes first). **Service more frequently when used in dusty conditions.**
2. Release retaining clips and remove filter element. Clean canister with a damp cloth.
3. Before installing a new filter element, inspect it by placing a bright light inside and rotate the element slowly, looking for any holes or tears in the paper. Also check gaskets for cuts or tears. Do not attempt to use a damaged element. Doing so will allow abrasive particles to enter the engine.
4. Inspect burp valve. Replace burp valve if it is cracked, torn, stays open, or is missing. See also "Burp Valve" on this page.
5. Install new Inner element into the new outer element as shown in Figure 5-13.
6. Install new outer filter element by inserting the open end in the canister first.

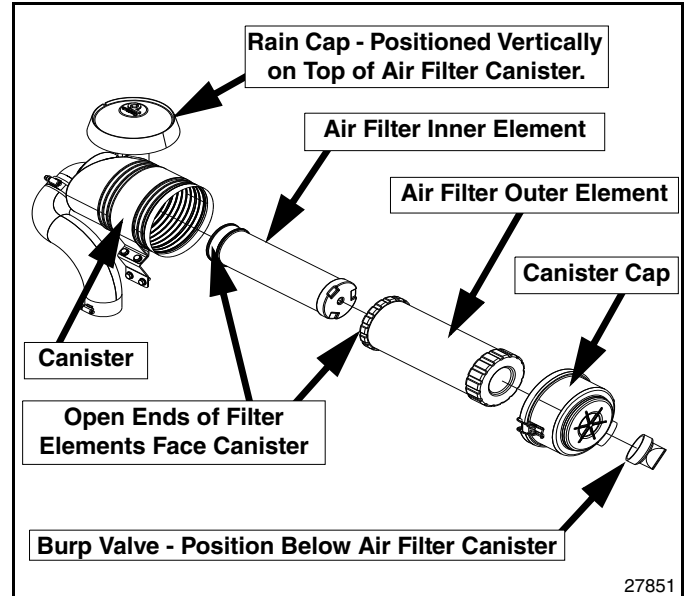

Canister Air Filter Kawasaki Engine  
Figure 5-13

**IMPORTANT:** Burp valve must be positioned below the canister to make certain it drains water away from the filter elements properly.

7. Reinstall canister cap with burp valve positioned below the canister. Make sure it seals all around the canister before latching retaining clips.
8. Check all fittings and clamps periodically for tightness. Inspect hoses for holes or cracks.
9. Periodically check engine intake hose for signs of ingested dust. Locate and repair source of ingested dirt.
10. Never operate a machine without an air filter installed.

### Burp Valve

Refer to Figure 5-14:

The burp valve is a highly important part of your dust filter. It opens and shuts, expelling collected dust and water as the engine's vacuum pressure pulsates. It also dumps dust collected in the filter canister when the engine stops running. If the burp valve is damaged, dust that would normally be discharged from the canister can collect on the filter element causing its life to be shortened. Replace the burp valve if it is open, cracked, torn, or missing.

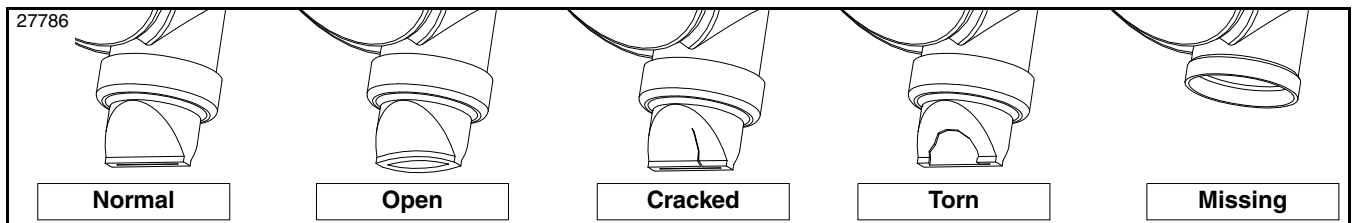

Figure 5-14

## Section 5: Maintenance & Lubrication

### Engine Air Filter Handling

Refer to Figure 5-13 on page 45:

Prevent costly and non-warrantable premature engine damage by maintaining the air filter properly. Many engine problems are due to improper handling of the air filter. Dust and dirt that gets past the air filter will damage engine cylinder, piston and bearings in a few hours.

Avoiding the following common mishandling:

- Over servicing
- Improper installation
- Damaged air filtering system
- Incorrect air filter element

#### Over Servicing

Over servicing occurs when an air filter element is inspected and/or replaced too often. Dust and dirt can fall off the filter element onto the canister where it can be sucked into the intake system. Only a few grams of dirt getting into an engine during each filter inspection can prematurely produce dust induced engine damage. A partially dirty air filter element is not harmful to the engine.

The air filter element should be changed before it becomes too dirty and restricts air flow to the engine hindering its performance. Replace the air filter element immediately should this happen. Engines that do not get proper amounts of air will draw in excessive amounts of gas causing premature engine damage.

The frequency of the air filter needing changing is largely determined by operating conditions. Dusty conditions will require more frequent servicing.

A dirty filter element should always be replaced with a new element. Improper cleaning procedures can get dust on the inside of the filter causing dirt induced and engine damage. **The air filter warranty expires upon cleaning or servicing a used filter in any manner. Land Pride does not warranty a dust induced engine damage if a used air filter element has been cleaned or serviced in any manner.**

### Improper Installation

Improper installation occurs when dust leaks past the seals. The filter element must be aligned within the canister and properly seated on both ends to prevent dirt from entering the engine.

### Damaged Air Filtering System

A damaged air filtering system occurs from mishandling of the filter element and operating the mower in areas that could damage the canister.

Banging and/or bumping the filter element against a solid object such as a tire or blowing the element with air can damage the seals and/or force dust and dirt particles through the filter media creating a hole for dirt to pass through to the engine.

Driving the mower carelessly over rough terrain, jutting sticks, heavy brush and severe rocks can damage the air cleaner canister. Periodically inspect the outside of the air cleaner canister for external damage and replace if necessary.

### Incorrect Air Filter Element

The air filter must remain intact to block passage of dirt and foreign particles. It must be of sufficient size and construction to withstand stresses, caused by rapid cycling of air volume demanded by the engine, without cracking or tearing under fatigue and pressure. Its filter elements must have the correct media composition, filter area, micron size and dimensions to properly filter the air of dirt while at the same time passing sufficient air to the engine.

Land Pride and the engine manufacturers have carefully selected a reliable filter designed to fit these needs. Always use genuine Land Pride filters. **Failure to use original equipment replacement parts is an alteration and will not be considered for warranty in the event of a dust induced engine damage.** See “Engine Specifications & Capacities” on page 53 for Land Pride air filter replacement numbers.



Section 5: Maintenance & Lubrication

Mower Blade Maintenance

Blade Inspection

Check mower blades daily, they are the key to power efficiency and a well groomed turf. Keep them sharp as a dull blade will tear rather than cut grass, leaving a brown ragged top on the grass within a few hours. A dull blade also requires more power from the engine.

Replace any blade which is bent, cracked, or broken.

**! WARNING**

DO NOT try to straighten a blade that is bent. Never weld a broken or cracked blade. ALWAYS replace with a new Land Pride blade to assure safety.

**! DANGER**

Never work with blades while engine is running or with blades engaged. Always push blade engagement switch down (OFF), move both control levers to neutral and then fully (OUT), set park brake (ON), and turn engine (OFF). Block up mower when you must work under it. Wear gloves when handling blades. Always check for blade damage if mower should strike a rock, branch, or other foreign object during mowing.

Blade Removal

Refer to Figure 5-15:

**IMPORTANT:** Blade mounting bolts have right hand threads. Turn blade bolts counterclockwise to loosen and clockwise to tighten.

1. Remove mower blade (#4) by grasping blade end with a rag or thick padded glove while loosening blade bolt (#2) with a 3/4" wrench.
2. Remove 1/2" blade bolt (#2), blade washer (#3) and mower blade (#4) from spindle assembly (#1).
3. Continue with "Blade Sharpening" on this page.

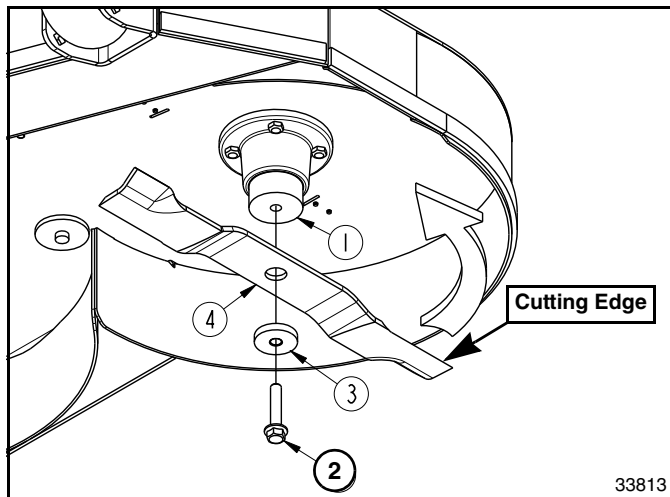

Blade Removal & Installation Illustration  
Figure 5-15

Blade Sharpening

**! DANGER**

Keep blades balanced when sharpening. An unbalanced blade may come loose and fly out from under the deck. Also, an unbalanced blade will shorten the spindle bearing's life.

**! CAUTION**

ALWAYS wear eye protection and gloves when sharpening a blade.

**NOTE:** Care should be taken in order not to remove any more material than necessary to sharpen blade.

1. Clean blade, blade washer and mounting surface of all debris before inspecting blade and sharpening.

Refer to Figure 5-16:

2. Lay blade on a flat surface and check blade to make sure it is not warped. Replace any blade that is warped.

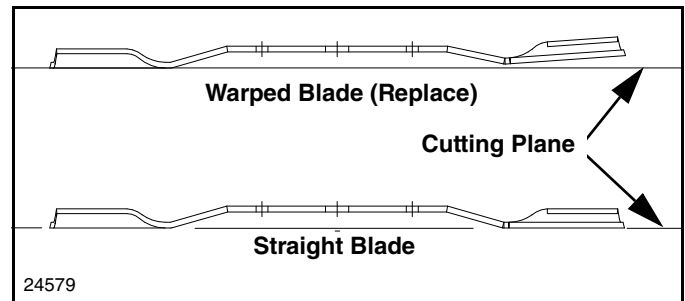

Comparison of Warped & Straight Blades  
Figure 5-16

Refer to Figure 5-17:

3. Lay blade on a flat surface and check both ends of blade to make sure it is not twisted. Replace any blade that is twisted.

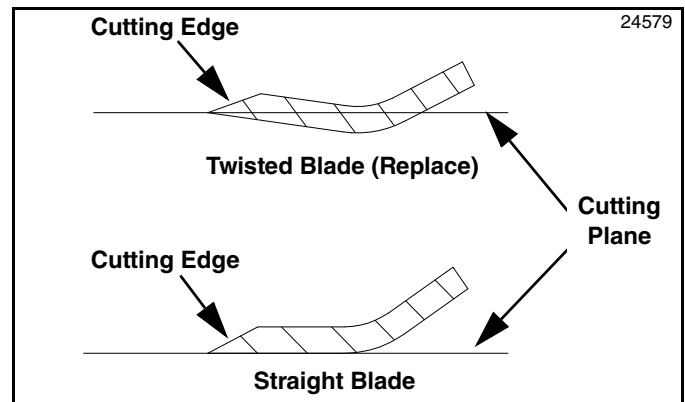

Comparison End View of Twisted & Straight Blades  
Figure 5-17

4. Check blade cutting edge. Replace blade if nicks are severe. Blade may be sharpened if cutting edge is dull or slightly nicked.

Refer to Figure 5-18:

**NOTE:** New mower blades are furnished with cutting edge parallel with back of blade. Do not sharpen blade to original parallel pattern. It is easier to get a straight cutting edge by resharpening the pattern to the one shown in Figure 5-19.

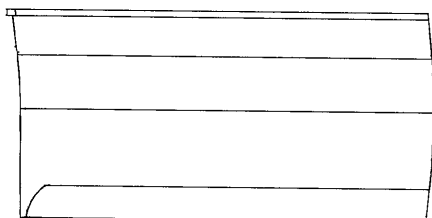

Original Cutting Edge Pattern

19075

**Blade Resharpener**  
Figure 5-18

Refer to Figure 5-19:

5. Sharpen blade by following the grinding pattern shown in Figure 5-19.
  - a. Grind cutting edge at the same bevel as the original angle. (27 1/2 degrees).
  - b. Sharpen only the top of the cutting edge to maintain sharpness.
  - c. Touch-up sharpening can be done with a file.

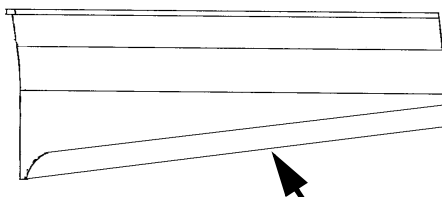

Resharpening Cutting Edge Pattern

19074

**Blade Resharpener**  
Figure 5-19

Refer to Figure 5-20:

6. Remove an equal amount of material from each end of the blade to keep blade in balance. Check blade balance as follows:
  - a. Positioning center of blade horizontally on a nail or shaft. See Figure 5-20.
  - b. If either end of the blade rotates downward, grind (remove) metal on that end until blade will balance horizontally on the nail or shaft.
  - c. Resharpened blades can be installed after they have been properly sharpened and balanced.



19046

**Blade Balancing**  
Figure 5-20

### Blade Installation

Refer to Figure 5-15 on page 47:



#### **WARNING**

*When mounting blades, rotate them after installation to ensure blade tips do not touch each other or sides of the mower.*



#### **WARNING**

*Failure to torque blade bolt properly may result in the blade coming loose and falling off causing a serious injury.*

**IMPORTANT:** Replace mower blades with Land Pride blades only.

**IMPORTANT:** Always install blades with cutting edge facing direction of blade spindle rotation and with wing tips pointing up towards bottom of deck. For correct blade rotation, see arrow in Figure 5-15.

**IMPORTANT:** Do not re-use blade bolts which have stripped, worn or undercut threads. For proper blade bolt torque value. see **“Additional Torque Values”** on page 60.

1. Install resharpened or new blade (#4) with blade washer (#3) and blade bolt (#2). Be careful not to cross thread blade bolt while installing it.
2. Tighten blade bolt to the correct torque. See **“Additional Torque Values”** on page 60 for correct torque values.

## Section 5: Maintenance & Lubrication

### End of Season & Long Term Storage

Take the following steps when storing mower at the end of the season and when unit will not be used for long periods to ensure readiness for the next mowing season.

**IMPORTANT:** Do not use a high pressure washer on or around the hydraulic transaxles. Water intrusion will result and void the warranty.

1. Remove all grass, dirt, trash, and grease that may have accumulated on the mower and moving parts.
2. Scrape off compacted dirt, trash, and grass clippings from the deck underside. A coating of oil may also be applied to the deck underside to minimize oxidation.
3. Clean and touch up all scrapes with Land Pride spray paint.
4. Check blades and blade bolts for wear and replace if necessary.
5. Check thoroughly for any worn or damaged parts that need replacing and order them from your nearest Land Pride dealer.
6. Thoroughly lubricate machine, according to lubrication instructions.
7. Prepare engine for storage:
  - a. Run engine for a minimum of 15 minutes.
  - b. Change engine oil while engine is still warm. See “**Change Engine Oil**” on page 44 for detailed instructions.
  - c. Drain fuel tank and run engine until it stops from lack of fuel. Gasoline evaporates if left in carburetor for long periods, forming gum and varnish deposits in the carburetor. These deposits will cause engine flooding and loss of power.
  - d. Service air cleaner. See “**Engine Air Filter**” on page 45.
  - e. Remove and replace fuel filter if not done in the previous 100 hours.
  - f. Remove spark plugs and pour a tablespoon of engine oil into each spark plug hole. Install plugs, but do not reconnect plug leads.
  - g. Crank engine with starter at least a dozen revolutions to distribute oil over cylinder walls and valve mechanism.
  - h. Clean dirt and chaff from cylinder fins, blower housing and muffler.
  - i. Clean exterior surface of engine. Spread a light film of oil over any exposed metal surfaces of engine that are subject to corrosion.
  - j. Check oil fill cap and fuel tank caps to make certain they are securely in place.

8. Store mower in a clean, dry place.
9. Block mower up so weight is off the tires.

**NOTE:** Do not deflate tires.

10. Protect battery from freezing temperatures. Disconnect the negative ground wire from battery to reduce chances of a slow electrical drain. Occasionally recharging battery during storage will extend battery life.





### New Season Preparation

The following service is required before starting the mower after storing it for a season:



**IMPORTANT:** Do not use a high pressure washer on or around the hydraulic transaxles. Water intrusion will result and void the warranty.

1. Clean mower, removing trash and dirt accumulation.
2. Check engine oil level.
3. Tighten any bolts that have loosened and make sure all hair pins, cotter pins, and clevis pins are in place.
4. Install all safety shields and review safety precautions listed in this manual.
5. Check and inflate tires to correct psi provided in “**Tire Inflation Chart**” on page 61.
6. Fill fuel tank with fresh gasoline.
7. Reconnect spark plug leads to spark plug.
8. Run machine at half speed for 5 minutes, checking operation of the control levers. Stop engine and check for oil leaks, loose fittings, and so forth.

### Lubrication Points

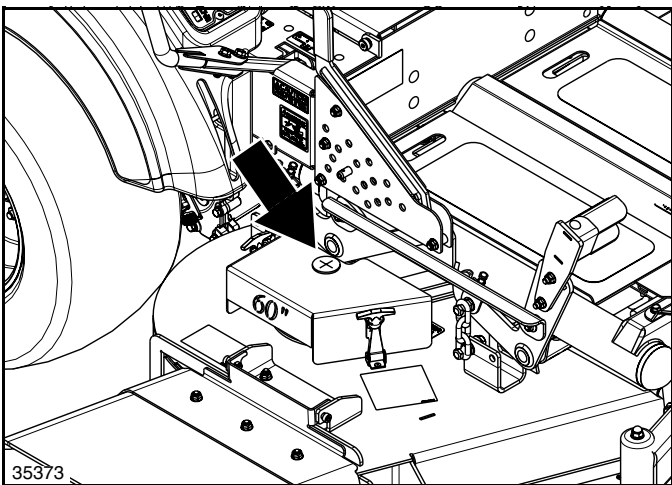
Lubrication Legend	 Multi-purpose spray lube	 Multi-purpose grease lube	 Multi-purpose oil lube	 50 hrs	Intervals in hours at which lubrication is required



	 25 Hours
---	--

#### Left Blade Spindle



Access through rubber slit in pulley cover.

1 - Zerk

Type of Lubrication: Multi-purpose Grease

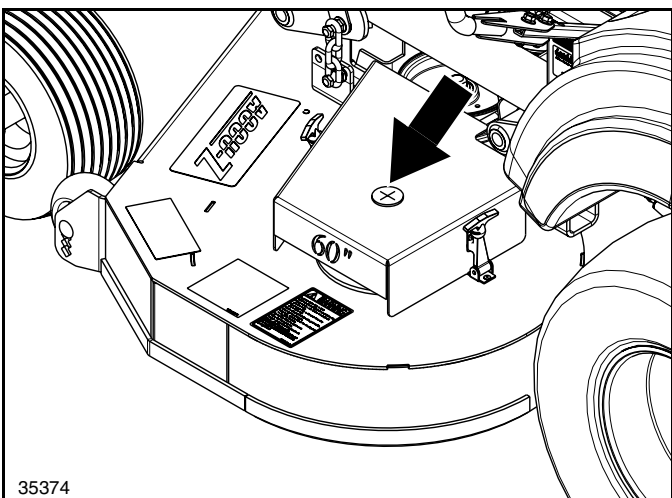
Quantity = As required



	 25 Hours
---	--

#### Right Blade Spindle



Access through rubber slit in pulley cover.

1 - Zerk

Type of Lubrication: Multi-purpose Grease

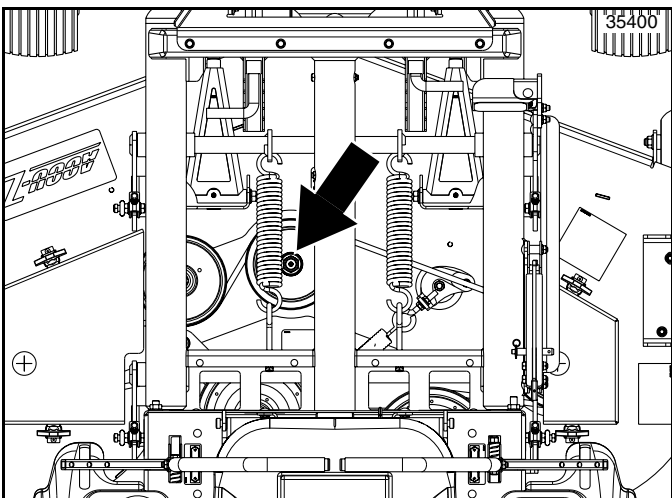
Quantity = As required



	 25 Hours
---	--

#### Center Blade Spindle

Lower deck fully down to access under the floor pan

1 - Zerk

Type of Lubrication: Multi-purpose Grease

Quantity = As required

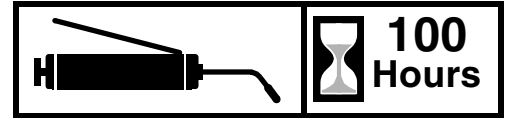
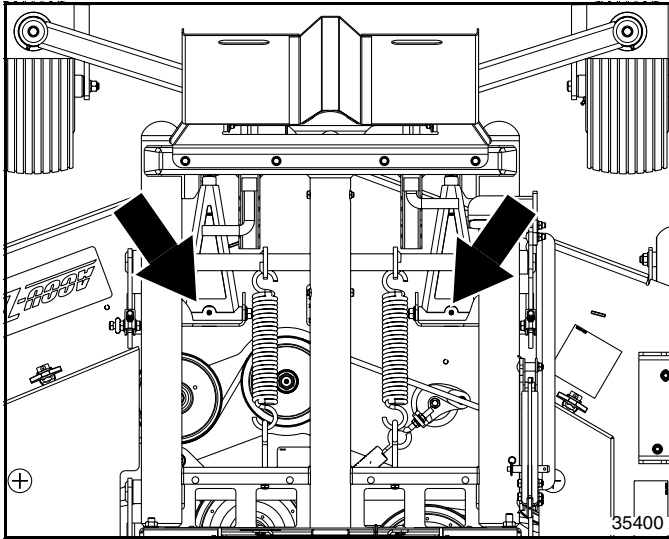

**Deck Struts**

Located beneath floor pan  
 2 - Zerks (One on each deck strut)  
 Type of Lubrication: Multi-purpose Grease  
 Quantity = As required

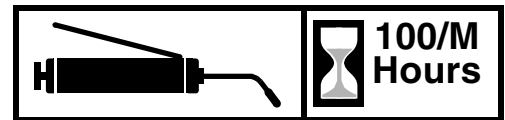
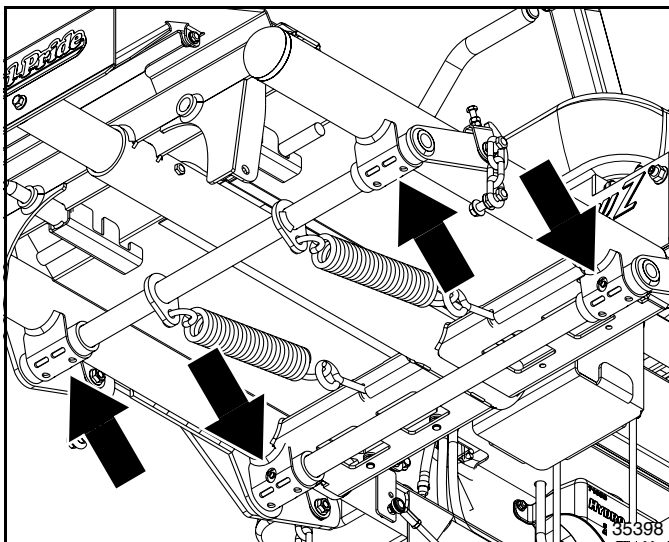

**Deck Lift Points**

Located above deck (Deck removed for clarity)  
 4 - Zerks (2 per side)  
 Type of Lubrication: Multi-purpose Grease  
 Quantity = As required every 100 hours or monthly, whichever comes first.

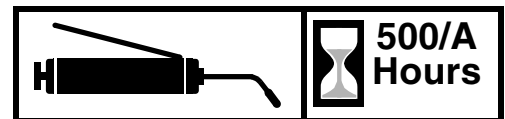
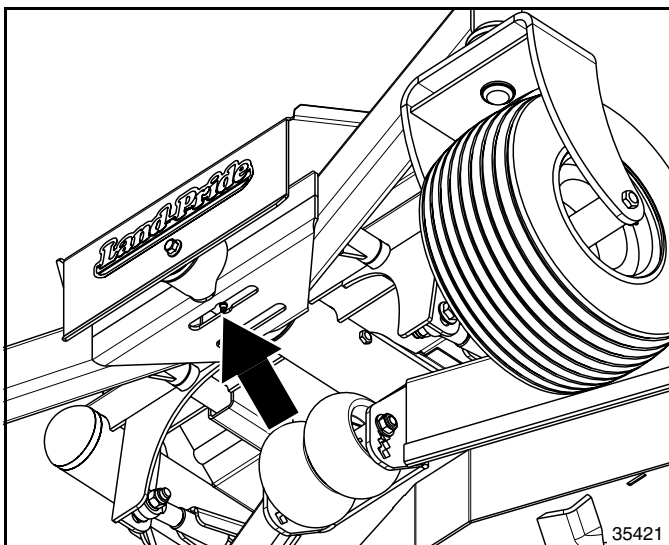

**Front Axle Center Pivot**

Located beneath floor pan  
 1- Zerk  
 Type of Lubrication: Multi-purpose Grease  
 Quantity = As required  
 Every 500 hrs. or annually, whichever comes first.

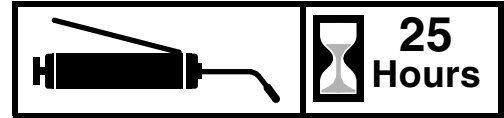
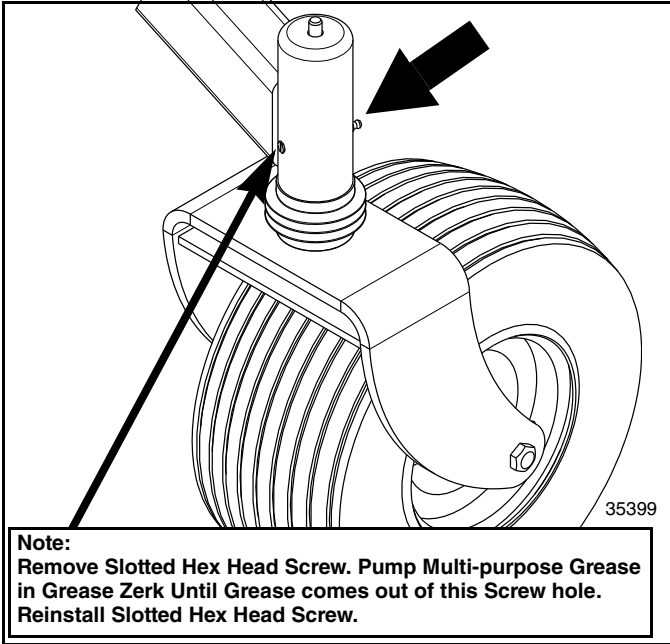

**Tele-Caster® Spindle Zerk**

Located on spindle of caster wheel

2 - Zerks (One on each caster wheel)

Quantity = As required (See note in illustration)

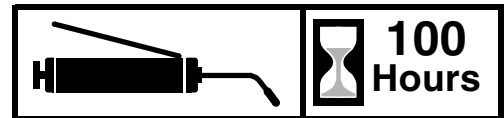
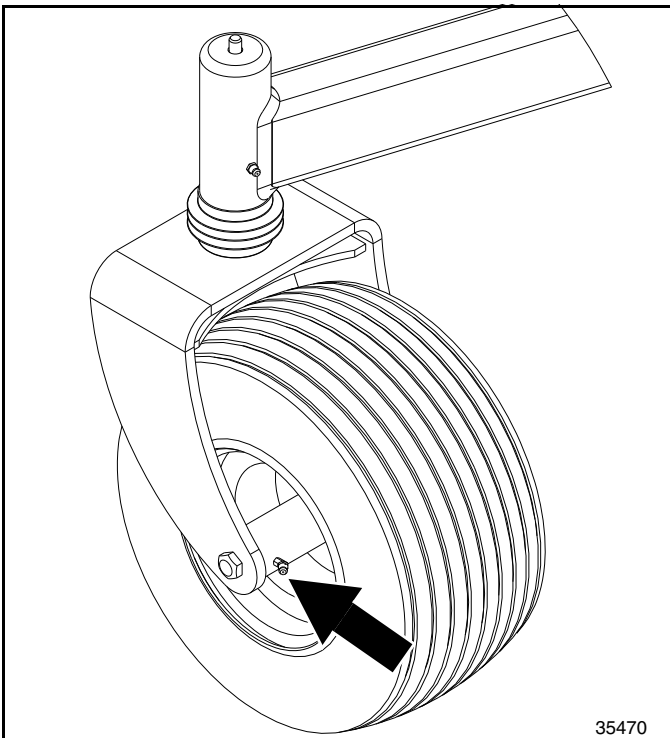

**Caster Wheel Bearing**

Located on hub of caster wheels

2 - Zerks (One on each caster wheel)

Type of Lubrication: Multi-purpose Grease

Quantity = As required



### Engine Specifications & Capacities

Mower Model No	ZT360 & ZT372
Engine Manufacture	Kawasaki
Horsepower	27
Engine Model Type	FX850V
Max Torque	54.3 ft. lbs. (73.6 N.m)
Charging System	12-volt, 13 amp w/Kawasaki Engine
Starter	12-volt (.8 KW) electric starter w/Kawasaki Engine
Ignition	Electronic
Governor	Mechanical
Fuel Type	Unleaded gasoline with octane rating of 87 or higher
Oil Cooling	Oil Cooler
Engine Cooling	Air cooled, Fly-wheel fan
Engine Type	4-stroke OHV, V-twin cylinder, gasoline
No of Cylinders	2
Displacement	52 cu. in. (852cc)
Compression Ratio	8.2:1
Spark Plug No.	BPR4ES (NGK)
Oil Capacity With Filter Change	2.1 US quarts
Oil Type	SAE 10W-30
Oil Filter Part No.	831-034C
Fuel Filter Part No.	831-031C
Commercial Remote Air Filter:	
Inner Filter Part No.	839-973C
Outer Filter Part No.	839-974C

### Hydrostatic Transaxle Specifications & Capacities

Mower Model No	ZT360 & ZT372
Transaxle Model Nos.	ZT-5400™
Gear Type	Cut Steel Gears
Number of Wheel Lugs	5
Traction Drive Type	Dual Hydrostatic Transmission
Hydraulic Motor/Pumps	Two variable displacement, axial piston type.
Hydraulic Motor/Pump Drive	V-belt drive from engine crankshaft
Hydraulic Oil Filter Part Number	71943
Hydraulic Oil Type	SAE 20W-50 engine oil
Hydraulic Oil Capacity - Per Side	164.8 -166.5 fl. oz. (1.287 - 1.301 gals.) to fill transaxle

### General Specifications & Capacities

Mower Model No	ZT360	ZT372
Weight Without Fuel	1400 lbs. w/deluxe seat 1410 lbs. w/suspension seat	1450 lbs. w/deluxe seat 1460 lbs. w/suspension seat
Width of Cut	60"	72"
Cutting Height	1" to 5" in 1/4" increments	
Trim Capacity (Left Side)	8 1/4" with standard tires 6 1/4" with offset tires	11 1/2"

Specifications to continue on next page.



### General Specifications & Capacities

Mower Model No	ZT360	ZT372
Overall Width (Chute Down)	74 1/4"	86 1/2"
Overall Width	52"	56"
At Rear Tires		
At Deck	74 1/4"	86 1/2"
Overall Length		90 1/4"
With ROPS Up		
With ROPS Down		95 1/2"
Overall Height		75"
With ROPS Up		
With ROPS Down		49 3/4"
Roll Over Protective Structure	Certified ROPS, includes seat belt	
Drive Tires	24 x 12.00 - 12, Turf tread	
Front Tires	13x6.5 - 6, Rib tire	
Hour Meter	Standard equipment	
Fuel Capacities	Twin 6 US GAL. tanks (Total fuel capacity = 12 US GAL.)	
Steering Type	Twin lever steering provides independent control of each drive wheel	
Twin Lever Steering Controls	Speed, forward, reverse, brake, and turns	
Steering Turning Radius	True zero degree. Turns with counter-rotating independent drive wheels	
Hydraulic Brake Service	Hydrostatic dynamic braking	
Park Brakes	Internal wet disk, manually actuated	
Ground Speed	Forward: 0-12 MPH Reverse: 0-6 MPH	
Wheel Drive	Single V-belt with spring tension idler pulley	
Electrical Operated Logic-Control Safety Features	Electric logic-control system governs blade engagement, forward & reverse motion, engine starting & running, and parking brake functions.	
Evaporative Emission Control System on EPA Compliant Mowers	This equipment uses a sealed fuel system which incorporates a non-vented fuel cap. Evaporative emissions are vented to the engine where they are combusted during normal engine operation.	
Seat Options	Deluxe cushion seat with arm rests Optional Suspension seat with arm rests	
Mainframe Construction	Welded steel	
Drive Motor Mount	Fabricated from 3/16" steel plate	
Front Caster Wheels	Free turning with roller bearings in greaseable sealed hubs.	
Front Caster Forks	3/8" steel	
Front Wheel Spindles & Suspension	Tele-Caster <sup>®</sup> with 1 1/2" spindles	
Pivoting Front Axle	Front axle can be locked or unlocked with 2 3/4" locking pins.	
Deck Thickness	3/16" deck with 1/4" doubler plate connecting spindle housing mounts.	
Box-Section Reinforced Front Edge	3/16" with solid 1" x 1/4" steel bar for reinforcement.	
Deck Trim Edges	Solid 1" x 1/4" steel bar for reinforced trim edge.	
Deck Housing Depth	5 3/16" deep, (room for high-capacity mowing)	
Deck Lift	Foot-operated deck height adjustment with transport position. Pin for setting height.	
Hand Operated Controls	Ignition switch, throttle lever, control levers, park brake lever, blade engagement switch, choke knob and fuel tank selector valve	
Indicators	Engine warning light, hour meter, and sight gauge	
Cup Holder	Two cup holders molded into the left side fuel tank. They accommodate nearly any cup size	
Cutting Heights	Height adjustment in 1/4" increments from 1" to 5"	
Mowing Blades	Heavy-duty, heat-treated, high-lift Fusion <sup>®</sup> edge	
	.25" x 2 1/2" x 21"	.25 x 2 1/2" x 25"
Blade Tip Speed	18,000 FPM	18,450 FPM
Blade Drive	Electric clutch drive with single V-belt to three spindles and spring tension idler pulley	



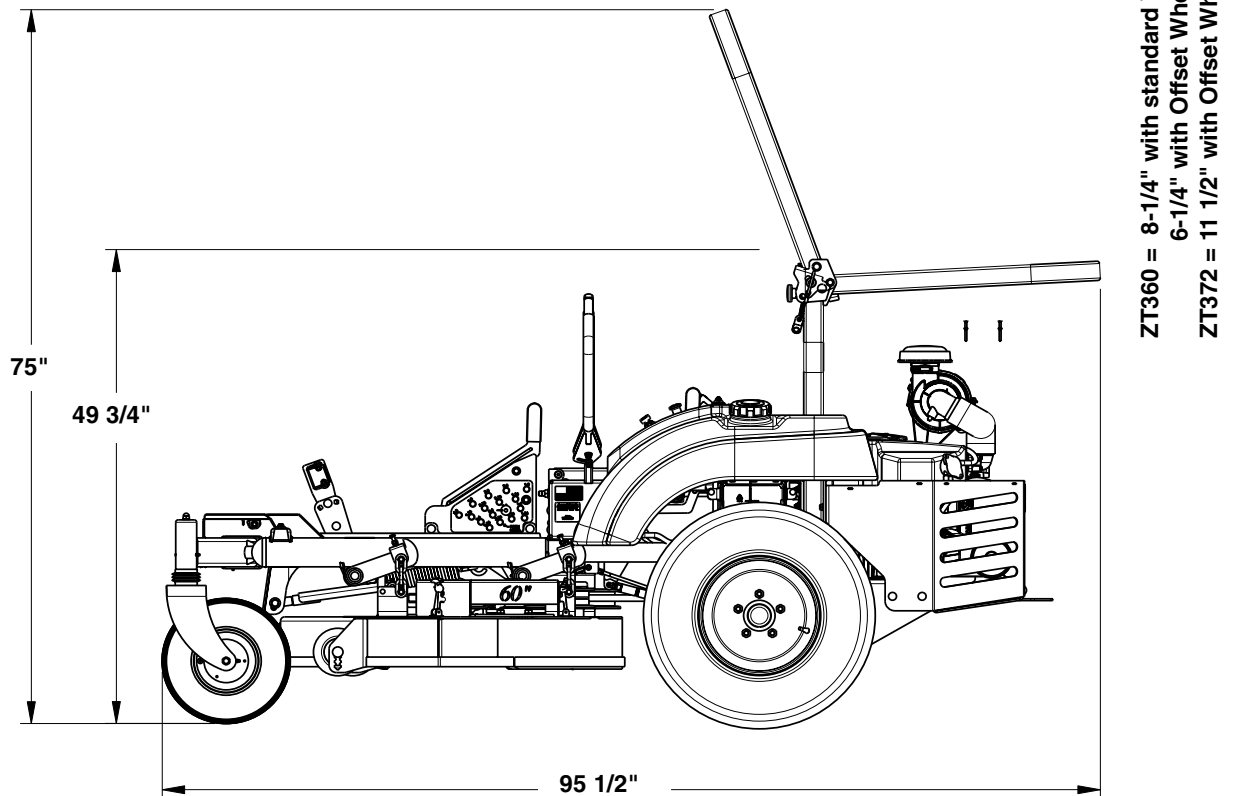
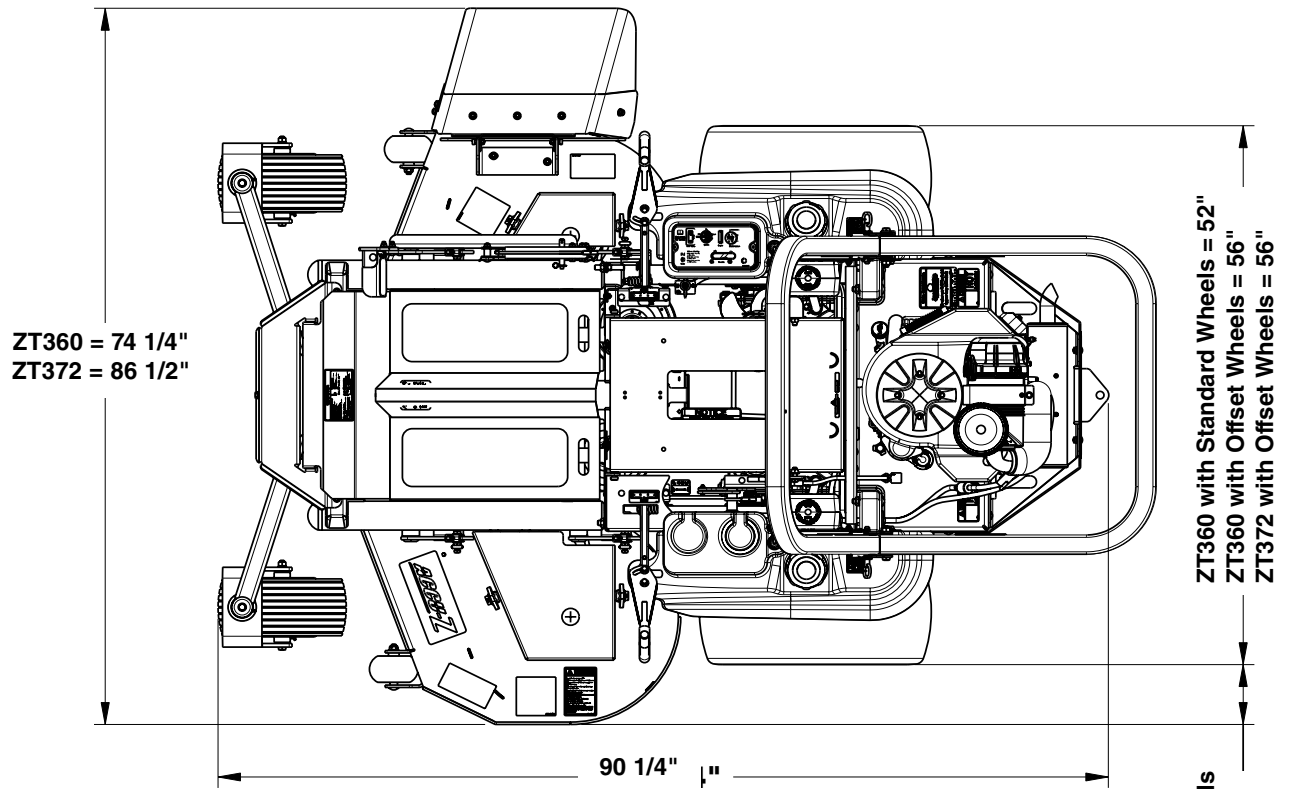

35405



### ZT360 & ZT372 Models

Features	Benefits
<b>Cutting width of 60" or 72"</b>	Sized right and priced right for ranch, estate owners, and commercial operators.
<b>Cutting height of 1" to 5"</b>	Provides a good range of cutting heights in 1/4" increments for any type of turf grass.
<b>ZT360 = 52" &amp; ZT372 = 56" Outside drive tire stance</b>	Provides excellent stability over uneven and hilly ground along with good maneuverability. ZT360 is also available, as an option, with 56" outside drive tire stance.
<b>High ground speed</b>	Forward 12 mph and reverse 6 mph for high productivity.
<b>Adjustable steering levers with comfort grip handles</b>	Wide range of adjustments to accommodate almost any size of operator. Grips are designed for operator comfort and sustained productivity.
<b>Spring suspension seat platform</b>	Helps smooth out the ride.
<b>Strong deck design</b>	New manufactured deck design has a great appearance on the outside, but tough parts on the inside. 3/16" Deck with 1/4" doubler plate, and a reinforced front edge.
<b>Rapid deck height adjustment</b>	The foot operated with spring assist deck lift and deck stop locator make for quick and easy precise cutting height adjustments.
<b>Easy clean-out deck top</b>	Deck allows air & debris to move across the top for improved belt cooling & easy clean out.
<b>Snap-on deck belt guards</b>	Deck belt guards can be hand removed easily without tools.
<b>Excellent trim capability</b>	Provides for good trim capability.
<b>Mid-mount deck design</b>	Puts deck closer to the operator's line of sight for more efficient and precise operation.
<b>Floating deck design</b>	Chain suspension design provides excellent flotation over uneven terrain.
<b>Four anti-scalp rollers</b>	Two located on deck ends and two located toward mid-deck keeps scalping to a minimum.
<b>Completely independent twin hydrostatic drives</b>	Separate expansion tanks eliminate the possibility of cross contamination.
<b>Premium wide stance drive tires</b>	Provide excellent traction, outstanding side-hill stability and a smooth ride.
<b>Ribbed front tires mounted in heavy duty pivoting caster forks</b>	Provide for a quick and reliable turning response.
<b>Tele-Caster® wheel spindles</b>	Spring loaded caster wheel spindles for superior shock absorption over rough terrain.
<b>Lockable floating front axle</b>	Floating front axle provides for smoother ride and optimal traction capability by keeping all tires equally in contact with the ground over uneven terrain. Locking front axle provides for a more uniform cut and curb or edge cutting without grounding or hanging up the deck.
<b>Electric clutch control</b>	Provides an easy smooth engagement of the mower blade drive system.
<b>Kevlar drive belts</b>	Drive belts made with Kevlar™ fiber provide long belt life. One hydrostatic pump drive belt and one deck drive belt.
<b>1" blade spindles mounted in ductile iron housings</b>	Additional 3/16" plate steel is added to the deck connecting the blade spindle housing mounts. Blade spindles, spindle housings and mounts are designed to handle heavy shock loads.
<b>Accessible blade spindle zerks</b>	Makes greasing the blade spindles easy.
<b>Heavy duty heat treated Fusion® high lift blades</b>	Made from highest quality .25" thick fusion treated steel for high wear and increase blade life. High lift design stands grass up before cutting.
<b>High blade tip speed</b>	Provides a clean quality cut. See specifications for actual speeds.
<b>Battery located under the seat</b>	Easy access to battery for servicing and maintaining.
<b>Kawasaki engine</b>	Proven engine to meet customer preferences with power and performance to spare.
<b>Electric start with choke control</b>	Keyed ignition and manual choke control are placed for one-handed starting convenience.
<b>Engine oriented for easy access</b>	Spark plugs, air filter, oil filter, & oil drain are placed easily within reach.
<b>Center Mounted Rear Engine</b>	Provides maximum mower stability, easy service access, increased leg room, and increased air flow around engine fins to extend engine life.
<b>Remote Air Intake</b>	All engines come standard with cyclonic type remote air intake to keep engines running clean and running longer.
<b>Engine oil cooler</b>	Keeps engine running at peak performance in warm weather conditions.



## ZT360 & ZT372 Models

Features	Benefits
<b>Isolated exhaust muffler</b>	Muffler is hidden and tucked down under to reduce noise and provide protection against burns.
<b>Ergonomically designed control console</b>	Instrumentation and console controls are positioned for easy visual or fingertip access.
<b>Hour meter</b>	Measure actual engine run time to monitor service intervals.
<b>Sleek styling EPA approved twin six gallon fuel tanks with sight gauge, extra large tethered fuel caps and vent valve</b>	12 Gallon fuel capacity for plenty of operating range and decreased downtime. Extra large fuel openings for easy fueling. Fuel caps are EPA approved, non vented, placed inboard and center mounted to protect caps from damage and prevent overflow spills on inclines. EPA vent valve helps stop fuel leaks in rollover accidents and sight gauge makes it easy to see low fuel level in tanks.
<b>Fuel tanks are vented to the engine carburetor</b>	Engine burns fuel vapors instead of vapors leaking into the atmosphere.
<b>Fuel selector/shutoff valve</b>	Provides on-the-go switching from one tank to another giving the operator time to finish the mowing job and to return to the refueling source before the mower stops running. Both tanks can be shutoff with this valve for servicing and storage.
<b>Molded-in dual cup holders and storage compartments</b>	Tanks are molded with cup holders that fit a wide variety of cups and are in easy access to the driver. A storage compartment molded next to the cups offer additional operator convenience.
<b>Lever activated park brake</b>	A manually activated over-center park brake lever located next to the operator's left side for easy activation and release of internal wet disk brakes. Mower will not move until brake is released.
<b>Hinged seat platform</b>	Tilts up for easy access to battery and drive components.
<b>Comfortable adjustable seat</b>	Deluxe Cushion or Molded Vinyl with suspension and adjustable positioning for operator comfort and sustained productivity.
<b>Seat safety interlocks</b>	Rising off of the seat with blades engaged will cut engine power and stop blade rotation. Engine cannot be started with blade engagement switch in "on" position.
<b>Hinged floor pan</b>	Provides quick and convenient service access to topside deck components without tools.
<b>Certified ROPS</b>	Certified ROPS for added operator protection.
<b>All Steel Pulleys</b>	Steel pulleys last longer.



### Troubleshooting Chart

Symptoms	Probable Causes	Suggested Remedies
<b>Starter motor does not crank engine.</b>	Control levers are not in neutral position and fully out.	Place control lever in neutral and fully out.
	Park brake not engaged (ON).	Engage park brake.
	Control lever interlock switch is not adjusted correctly.	Have your dealer re-adjust the interlock switch.
	Blade engagement switch is engaged.	Disengage blade switch.
	Weak or dead battery.	Recharge or replace.
	Loose or broken switches and/or damaged electrical wiring.	Repair or replace switches and electrical wiring.
	Other causes	See Engine Operator's Manual.
<b>Engine cranks but does not start.</b>	No fuel in the fuel tanks.	Fill tank.
	Fuel filter and/or fuel line plugged.	Replace fuel filter and/or fuel line.
	Other causes	See Engine Operator's Manual.
<b>Engine runs with continuous misfiring, runs unevenly or runs erratically.</b>	Other causes	See Engine Operator's Manual.
<b>Grass cutting is ragged or uneven.</b>	Dull, bent, or broken cutting blades.	Sharpen or replace cutting blades.
	Deck full of wet sticky grass.	Clean underside of deck.
	Cutting blades are not operating at full engine speed.	Increase engine rpms to full speed (3600 rpm) Check engine speed with Land Pride Inductive Tachometer, Part No. 890-909C.
	Belt over center take-up is loose.	Tension over center take-up.
	Worn or broken belt.	Replace worn and broken belt. See " <b>Belt Maintenance</b> " on page 38.
	Deck is not level.	Check air pressure in all 4 tires Make level adjustments to the deck. See " <b>Deck Cutting Height and Leveling</b> " on page 28.
<b>Loss of power or system will not operate in either direction.</b>	Bypass valve is open.	Close bypass valve. See " <b>Moving Mower with Stalled Engine</b> " page 17.
	Bypass assembly is sticking.	See your dealer.
	Mower is loaded excessively.	Reduce load on mower.
	Steering hardware is loose or lost.	Replace steering hardware.
	Bad ground drive belt and/or pump idler pulley.	Replace belt and/or idler pulley. Tighten idler pulley if loose.
	Loose, lost, or broken belt take-up spring.	Reattach or replace belt take-up spring.
	Restrictions in air cleaner.	Service air cleaner.
	Internal interference or leakage in transaxle.	See your dealer.
	Oil level in transaxle is low.	Fill transaxle to the correct level.
	Poor compression.	See your dealer.
	Steering linkage is bent or needs adjustment.	Adjust linkage. See " <b>Steering Adjustments</b> " on page 26.
	Air is trapped in the hydraulic system.	Purge transaxle of air or see your dealer.
Other causes	See Engine Operator's Manual.	



### Troubleshooting Chart

Symptoms	Probable Causes	Suggested Remedies
<b>Engine is overheating.</b>	Air intake screen or cleaning fins clogged.	Clean screen and fins.
	Not operating engine at rated speed.	Increase engine speed to 3600 rpm.
	Other causes.	See Engine Operator's Manual.
<b>Low engine oil pressure (Indicated by oil light being on while engine is running.)</b>	Low oil level.	Add oil.
	Oil diluted or too light.	Change oil and check for source of contamination.
<b>High engine oil consumption.</b>	Other causes.	See your dealer.
<b>Mower is jerky when starting to travel.</b>	Steering linkage is bent or needs adjustment.	Adjust linkage. See " <b>Steering Adjustments</b> " on page 26.
	Drive belt is slipping.	Retention or replace drive belt.
	Pulleys are worn or damaged.	Replace worn and damaged pulleys.
	Transaxle is faulty.	See your dealer.
<b>Steering levers do not return to neutral.</b>	Steering linkage is out of adjustment.	Adjust linkage. See " <b>Steering Adjustments</b> " on page 26.
	Steering linkage is bent, broken, or missing.	Replace steering linkage. See item 1 on page 26.
	Transaxle neutral return spring is broken or missing.	Replace transaxle neutral return spring.
<b>Mower creeps when steering control levers are in neutral.</b>	Steering linkage is out of adjustment.	Adjust linkage. See " <b>Steering Adjustments</b> " on page 26.
<b>Mower circles or veers in one direction.</b>	Tires are not inflated properly.	Inflate tires to the correct tire pressure.
	Steering linkage is bent or needs adjustment.	Adjust linkage. See " <b>Steering Adjustments</b> " on page 26.
	Bypass assembly is sticking.	See your dealer.
<b>Mower travels only in one direction.</b>	Steering linkage is bent or needs adjustment.	Repair or replace linkage.
	Drive belt is slipping.	Re-tension or replace drive belt.
	Pulleys are worn or damaged.	Replace worn and damaged pulleys.
	Transaxle is faulty.	See your dealer.
<b>Transaxle is noisy.</b>	Oil level in transaxle is low.	Fill transaxle to the correct level.
	Oil is contaminated.	See your dealer.
	Transaxle has some loose parts.	See your dealer.
	Bypass assembly is sticking.	
	Air is trapped in the hydraulic system.	Purge transaxle of air or see your dealer.
<b>Transaxle leaks oil.</b>	Seals, housing, or gaskets are damaged.	See your dealer.
	Air is trapped in hydraulic system.	Purge transaxle of air or see your dealer.
<b>Transaxles operates hot.</b>	Hydro-drive faulty.	See your dealer.
	Not operating engine at rated speed.	Increase engine speed to 3600 rpm.
<b>Front pivot lock pins won't engage or are hard to disengage.</b>	Not on level ground.	Move unit to a level surface.
	Tires are not properly inflated.	Check pressure in tires and add air as needed. See " <b>Tire Inflation Chart</b> " on page 61.

# Table of Contents

## Section 9: Torque & Tire Inflation Charts



Torque Values Chart													
Bolt Size (inches)	Bolt Head Identification						Bolt Size (Metric)	Bolt Head Identification					
	 Grade 2		 Grade 5		 Grade 8			 Class 5.8		 Class 8.8		 Class 10.9	
in-tpi <sup>1</sup>	N · m <sup>2</sup>	ft-lb <sup>3</sup>	N · m	ft-lb	N · m	ft-lb	mm x pitch <sup>4</sup>	N · m	ft-lb	N · m	ft-lb	N · m	ft-lb
1/4" - 20	7.4	5.6	11	8	16	12	M 5 X 0.8	4	3	6	5	9	7
1/4" - 28	8.5	6	13	10	18	14	M 6 X 1	7	5	11	8	15	11
5/16" - 18	15	11	24	17	33	25	M 8 X 1.25	17	12	26	19	36	27
5/16" - 24	17	13	26	19	37	27	M 8 X 1	18	13	28	21	39	29
3/8" - 16	27	20	42	31	59	44	M10 X 1.5	33	24	52	39	72	53
3/8" - 24	31	22	47	35	67	49	M10 X 0.75	39	29	61	45	85	62
7/16" - 14	43	32	67	49	95	70	M12 X 1.75	58	42	91	67	125	93
7/16" - 20	49	36	75	55	105	78	M12 X 1.5	60	44	95	70	130	97
1/2" - 13	66	49	105	76	145	105	M12 X 1	90	66	105	77	145	105
1/2" - 20	75	55	115	85	165	120	M14 X 2	92	68	145	105	200	150
9/16" - 12	95	70	150	110	210	155	M14 X 1.5	99	73	155	115	215	160
9/16" - 18	105	79	165	120	235	170	M16 X 2	145	105	225	165	315	230
5/8" - 11	130	97	205	150	285	210	M16 X 1.5	155	115	240	180	335	245
5/8" - 18	150	110	230	170	325	240	M18 X 2.5	195	145	310	230	405	300
3/4" - 10	235	170	360	265	510	375	M18 X 1.5	220	165	350	260	485	355
3/4" - 16	260	190	405	295	570	420	M20 X 2.5	280	205	440	325	610	450
7/8" - 9	225	165	585	430	820	605	M20 X 1.5	310	230	650	480	900	665
7/8" - 14	250	185	640	475	905	670	M24 X 3	480	355	760	560	1050	780
1" - 8	340	250	875	645	1230	910	M24 X 2	525	390	830	610	1150	845
1" - 12	370	275	955	705	1350	995	M30 X 3.5	960	705	1510	1120	2100	1550
1-1/8" - 7	480	355	1080	795	1750	1290	M30 X 2	1060	785	1680	1240	2320	1710
1-1/8" - 12	540	395	1210	890	1960	1440	M36 X 3.5	1730	1270	2650	1950	3660	2700
1-1/4" - 7	680	500	1520	1120	2460	1820	M36 X 2	1880	1380	2960	2190	4100	3220
1-1/4" - 12	750	555	1680	1240	2730	2010	<sup>1</sup> in-tpi = nominal thread diameter in inches-threads per inch <sup>2</sup> N · m = newton-meters <sup>3</sup> ft-lb= foot pounds <sup>4</sup> mm x pitch = nominal thread diameter in millimeters x thread pitch						
1-3/8" - 6	890	655	1990	1470	3230	2380							
1-3/8" - 12	1010	745	2270	1670	3680	2710							
1-1/2" - 6	1180	870	2640	1950	4290	3160							
1-1/2" - 12	1330	980	2970	2190	4820	3560							
Torque tolerance + 0%, -15% of torquing values. Unless otherwise specified use torque values listed above.													
Additional Torque Values													
Drive Wheel Lug Nuts (1/2"-20 UNF)								75 ft-lbs.			102 N-m		
Blade Spindle bolts (1/2"-20 UNF x 2 1/2" GR8)								60 to 70 ft-lbs.			82 to 95 N-m		
Spindle Housing Flange Bolts								55 ft-lbs			75 N-m		
Idler Pulley Bolts (5/8"-11 UNC GR5)								130 ft-lbs.			176 N-m		
Electric Clutch Bolt (7/16"- 20 UNF GR8)								50 to 55 ft-lbs.			68 to 75 N-m		
Hydro-Gear Top Port Plug (See Figure 5-8 on page 40, Item 4.)								15 ft-lbs.			20 N-m		
Chock & Throttle Cable Clamp Screws								35 in-lbs.			3.9 N-m		
Transaxle Oil Filter Cap								480-580 in-lbs.			54.23-65.53 N-m		



<b>Tire Inflation Chart</b>	
<b>Tire</b>	<b>Inflation PSI</b>
<b>Rear Drive Wheels</b>	8 to 12
<b>Front Caster Wheels</b>	8 to 12

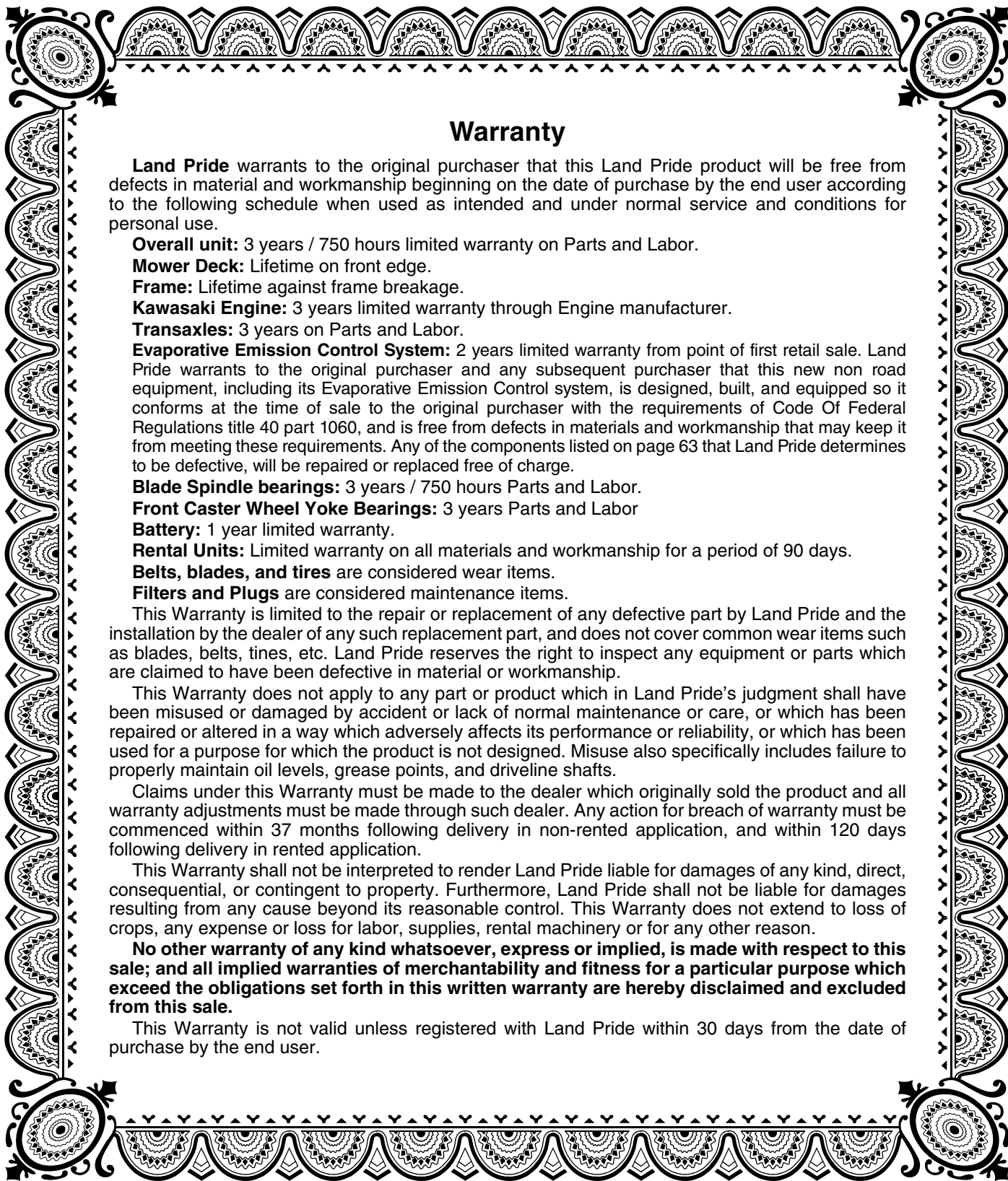

## Warranty

Land Pride warrants to the original purchaser that this Land Pride product will be free from defects in material and workmanship beginning on the date of purchase by the end user according to the following schedule when used as intended and under normal service and conditions for personal use.

**Overall unit:** 3 years / 750 hours limited warranty on Parts and Labor.

**Mower Deck:** Lifetime on front edge.

**Frame:** Lifetime against frame breakage.

**Kawasaki Engine:** 3 years limited warranty through Engine manufacturer.

**Transaxles:** 3 years on Parts and Labor.

**Evaporative Emission Control System:** 2 years limited warranty from point of first retail sale. Land Pride warrants to the original purchaser and any subsequent purchaser that this new non road equipment, including its Evaporative Emission Control system, is designed, built, and equipped so it conforms at the time of sale to the original purchaser with the requirements of Code Of Federal Regulations title 40 part 1060, and is free from defects in materials and workmanship that may keep it from meeting these requirements. Any of the components listed on page 63 that Land Pride determines to be defective, will be repaired or replaced free of charge.

**Blade Spindle bearings:** 3 years / 750 hours Parts and Labor.

**Front Caster Wheel Yoke Bearings:** 3 years Parts and Labor

**Battery:** 1 year limited warranty.

**Rental Units:** Limited warranty on all materials and workmanship for a period of 90 days.

**Belts, blades, and tires** are considered wear items.

**Filters and Plugs** are considered maintenance items.

This Warranty is limited to the repair or replacement of any defective part by Land Pride and the installation by the dealer of any such replacement part, and does not cover common wear items such as blades, belts, tines, etc. Land Pride reserves the right to inspect any equipment or parts which are claimed to have been defective in material or workmanship.

This Warranty does not apply to any part or product which in Land Pride's judgment shall have been misused or damaged by accident or lack of normal maintenance or care, or which has been repaired or altered in a way which adversely affects its performance or reliability, or which has been used for a purpose for which the product is not designed. Misuse also specifically includes failure to properly maintain oil levels, grease points, and driveline shafts.

Claims under this Warranty must be made to the dealer which originally sold the product and all warranty adjustments must be made through such dealer. Any action for breach of warranty must be commenced within 37 months following delivery in non-rented application, and within 120 days following delivery in rented application.

This Warranty shall not be interpreted to render Land Pride liable for damages of any kind, direct, consequential, or contingent to property. Furthermore, Land Pride shall not be liable for damages resulting from any cause beyond its reasonable control. This Warranty does not extend to loss of crops, any expense or loss for labor, supplies, rental machinery or for any other reason.

**No other warranty of any kind whatsoever, express or implied, is made with respect to this sale; and all implied warranties of merchantability and fitness for a particular purpose which exceed the obligations set forth in this written warranty are hereby disclaimed and excluded from this sale.**

This Warranty is not valid unless registered with Land Pride within 30 days from the date of purchase by the end user.

**IMPORTANT:** The Online Warranty Registration should be completed by the dealer at the time of purchase. This information is necessary to provide you with quality customer service.

**Model Number** \_\_\_\_\_

**Serial Number** \_\_\_\_\_



Section 10: Warranty

Evaporative Emission Control Components

Refer to Figure 10-1:

1. CAP, NON-VENTED FUEL
2. GAS TANK FITTING W/NUT&WASHER
3. CLAMP PINCH FOR .50 OD HOSE
4. CLAMP WRM DRV (.21-.63)
5. HFSS 3/8-16X5/8 GR5 YELLOW DIE
6. LH FUEL TANK, COMPLIANT
7. RH FUEL TANK, COMPLIANT
8. VALVE, FUEL SELECTOR
9. TEE 1/4HB POLYPROP
10. FUEL FILTER
11. HOSE RUBBER.25ID/.5 OD SAE30R7
12. HOSE RUBBER.25ID/.5 OD SAE30R7
13. HOSE RUBBER.25ID/.5 OD SAE30R7
14. HOSE RUBBER.25ID/.5 OD SAE30R7
15. HOSE RUBBER.25ID/.5 OD SAE30R7
16. HOSE RUBBER.25ID/.5 OD SAE30R7
17. GROMMET, FUEL TANK FITTING
18. ROV ASY
19. SV KIT, EPA VALVE & GROMMET

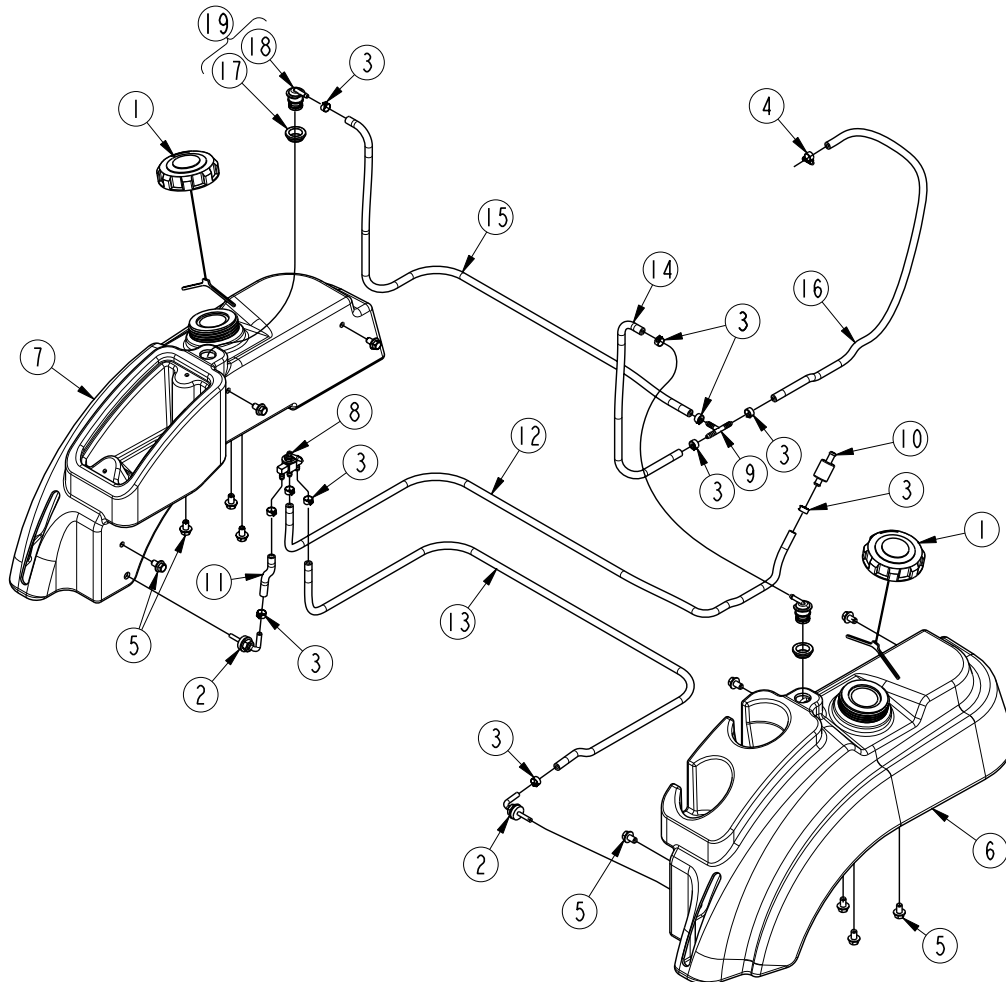

33823

Evaporative Emission Control Components  
Figure 10-1



Corporate Office: P.O. Box 5060  
Salina, Kansas 67402-5060 USA  
[www.landpride.com](http://www.landpride.com)

---